

# Silentia Series N

For profile and thicker doors.

Hinges with adjustable integrated soft-close mechanism operated by twin silicone-oil dampers housed in the hinge cup.

The decelerating effect is adjusted by using a simple switch.

Dimensions of the Ø 40 mm cup.

## Technical features

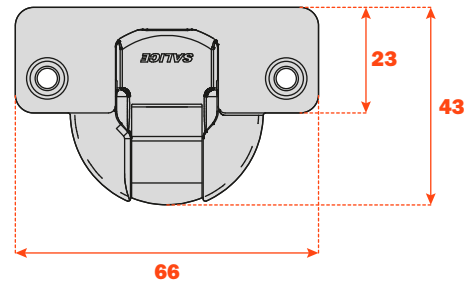

Constant "L" value of 1.5 mm (it does not change during side adjustment).

Approx. number of hinges required according to the door dimension and weight.

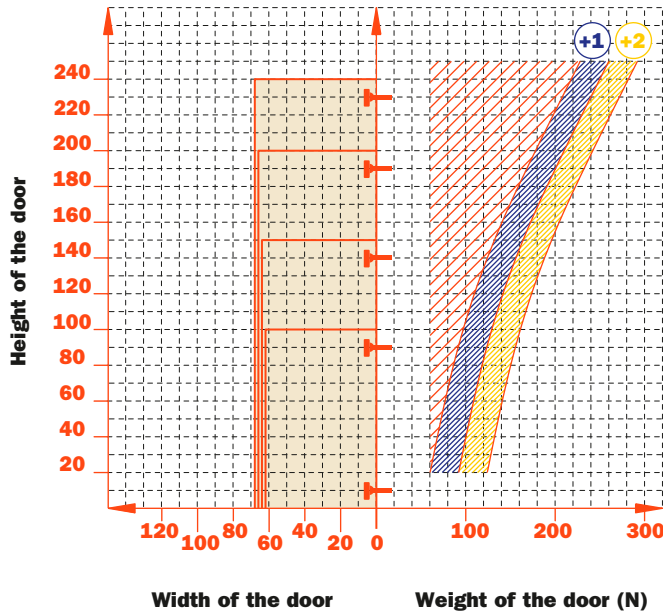

## Adjustments



Compensated side adjustment from -1.5 mm to +4.5 mm.  
 Height adjustment  $\pm 2$  mm.  
 Depth adjustment with Series 200 mounting plates +2.8 mm.  
 Depth adjustment with Domi mounting plates from -0.5 mm to +2.8 mm.



## Mounting plates

Symmetrical and asymmetrical bright nickel plated steel or die-cast Series 200 mounting plates.  
 Snap-on assembly on Domi mounting plates.  
 Positioning with pre-determined stop on traditional Series 200 mounting plates.

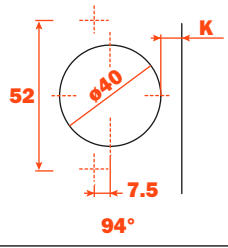
N.B. : Use POZIDRIVE No. 2 screwdrivers for all screws.

**Drillings and fixings**

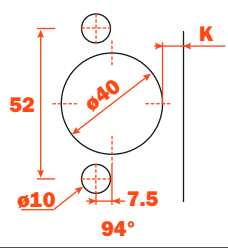
	
<p><b>Wood screw</b></p> 	<p><b>A</b></p>

	
<p><b>Dowel</b></p> 	<p><b>B</b></p>

**Use this table to identify the available drillings and fixings.  
 Fill the third position of the hinge code number with the letter or the number  
 corresponding to your choice. I.e.: CN\_7AE9.**

↑  
 Fill this position with the chosen letter or number.

**Series N - 94° opening**



**Technical information**

Hinges with adjustable integrated soft-close mechanism operated by twin silicone-oil dampers housed in the hinge cup. The decelerating effect is adjusted by using a simple switch.

For profile and thicker doors, max. 40 mm.

15.5 mm deep cup.

94° opening.

Possible drilling distance on the door (K): from 3 to 14 mm.

Compatible with all traditional Series 200 mounting plates and with all Domi snap-on mounting plates.

**Space needed to open the door**

	T=	20	21	22	23	24	25	26	27	28	29	30	31	32	33	34	35	36	37	38	39	40	L=
K=3	<b>A=</b>	0.3	0.4	0.6	0.7	0.9	1.0	1.2	1.4	1.7	1.9	2.2	2.4	2.9	3.8	4.7	5.7	6.6	7.6	8.6	9.5	10.5	0.0
K=4	<b>A=</b>	0.3	0.4	0.6	0.7	0.9	1.0	1.2	1.4	1.6	1.9	2.1	2.4	2.7	3.2	4.1	5.0	6.0	6.9	7.9	8.8	9.8	0.0
K=5	<b>A=</b>	0.3	0.4	0.6	0.7	0.8	1.0	1.2	1.4	1.6	1.8	2.1	2.4	2.7	3.0	3.5	4.4	5.3	6.2	7.2	8.1	9.1	0.0
K=6	<b>A=</b>	0.3	0.4	0.5	0.7	0.8	1.0	1.2	1.4	1.6	1.8	2.1	2.3	2.6	2.9	3.2	3.9	4.7	5.6	6.6	7.5	8.4	0.0
K=7	<b>A=</b>	0.3	0.4	0.5	0.7	0.8	1.0	1.2	1.4	1.6	1.8	2.0	2.3	2.6	2.9	3.2	3.5	4.2	5.1	6.0	6.9	7.8	0.0
K=8	<b>A=</b>	0.3	0.4	0.5	0.7	0.8	1.0	1.1	1.3	1.5	1.8	2.0	2.3	2.5	2.8	3.1	3.5	3.8	4.6	5.4	6.3	7.2	0.0
K=9	<b>A=</b>	0.3	0.4	0.5	0.7	0.8	1.0	1.1	1.3	1.5	1.7	2.0	2.2	2.5	2.8	3.1	3.4	3.8	4.2	5.0	5.8	6.7	0.0
K=10	<b>A=</b>	0.3	0.4	0.5	0.6	0.8	0.9	1.1	1.3	1.5	1.7	1.9	2.2	2.4	2.7	3.0	3.3	3.7	4.1	4.6	5.4	6.2	0.8
K=11	<b>A=</b>	0.3	0.4	0.5	0.6	0.8	0.9	1.1	1.3	1.5	1.7	1.9	2.2	2.4	2.7	3.0	3.3	3.6	4.0	4.4	5.0	5.8	1.8
K=12	<b>A=</b>	0.3	0.4	0.5	0.6	0.8	0.9	1.1	1.3	1.5	1.7	1.9	2.1	2.4	2.6	2.9	3.2	3.6	3.9	4.3	4.7	5.4	2.8
K=13	<b>A=</b>	0.3	0.4	0.5	0.6	0.8	0.9	1.1	1.2	1.4	1.6	1.9	2.1	2.3	2.6	2.9	3.2	3.5	3.9	4.2	4.6	5.1	3.8
K=14	<b>A=</b>	0.3	0.4	0.5	0.6	0.7	0.9	1.1	1.2	1.4	1.6	1.8	2.1	2.3	2.6	2.8	3.1	3.5	3.8	4.1	4.5	5.0	4.8

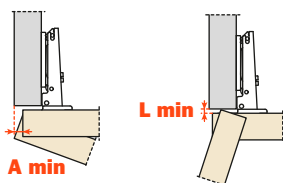

The above values are calculated on the assumption that the doors have square edges. They are reduced if the doors have radiussed edges.

**Projection of the door**

Projection of the door from the cabinet side at the max. opening. The figures are based on a straight arm hinge, H=0 mm thickness of mounting plate and K value = 3 mm.

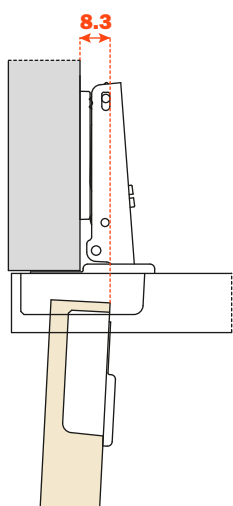

**“C” value**

With this formula you can obtain the max. thickness of the moulded door that can be opened without touching adjacent carcase sides, doors or walls, whilst bearing in mind the above L-K-T values.

$$C=27.3 + K+ A$$

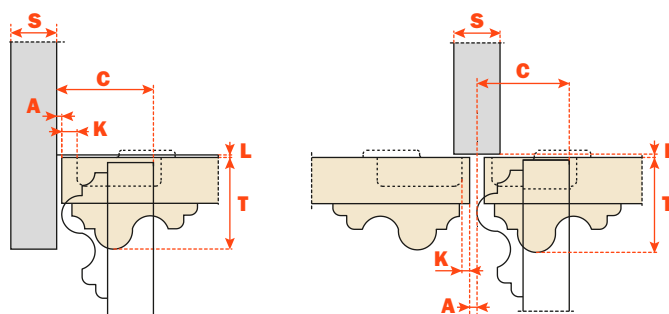

**Arm 0 and arm 9**

**Packing** • Boxes 300 pcs. • Pallets 7.200 pcs.

**Arm 22**

**Packing** • Boxes 150 pcs. • Pallets 3.600 pcs.

Use these formulas to determine the type of hinge arm, the drilling distance "K" and the height of the mounting plate "H" which is necessary to solve each application problem.

Use the tables "Drillings and fixings" at page 7 to complete the code number of the desired hinge.

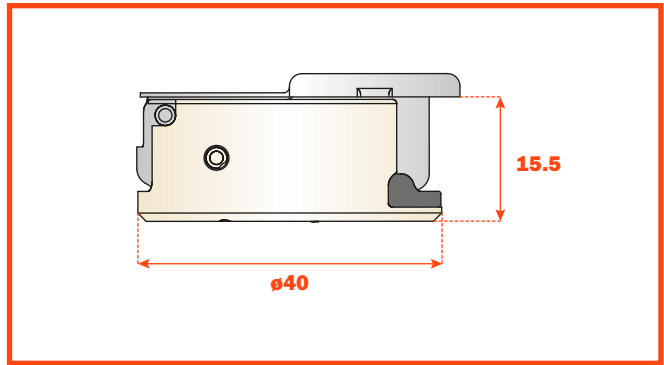

**Arm 0**

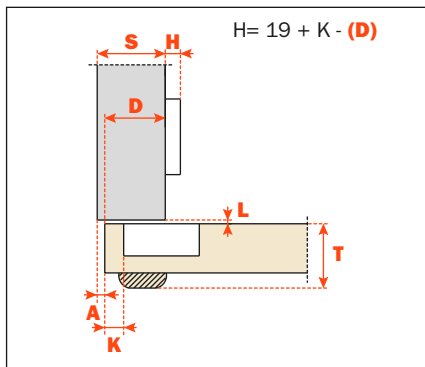

**CN\_7AE9**

**Arm 9**

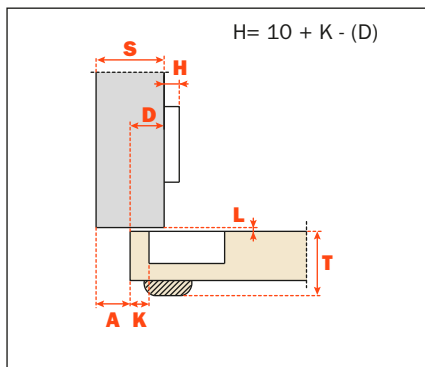

**CN\_7GE9**

**Arm 22**

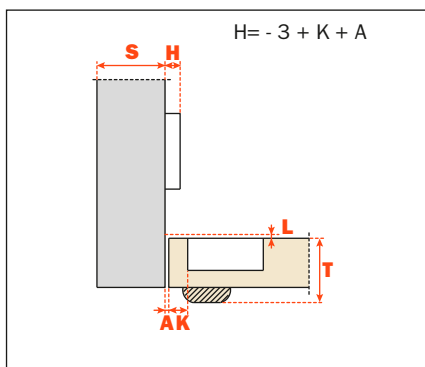

**CN\_7PE9**