

LIBRA H7

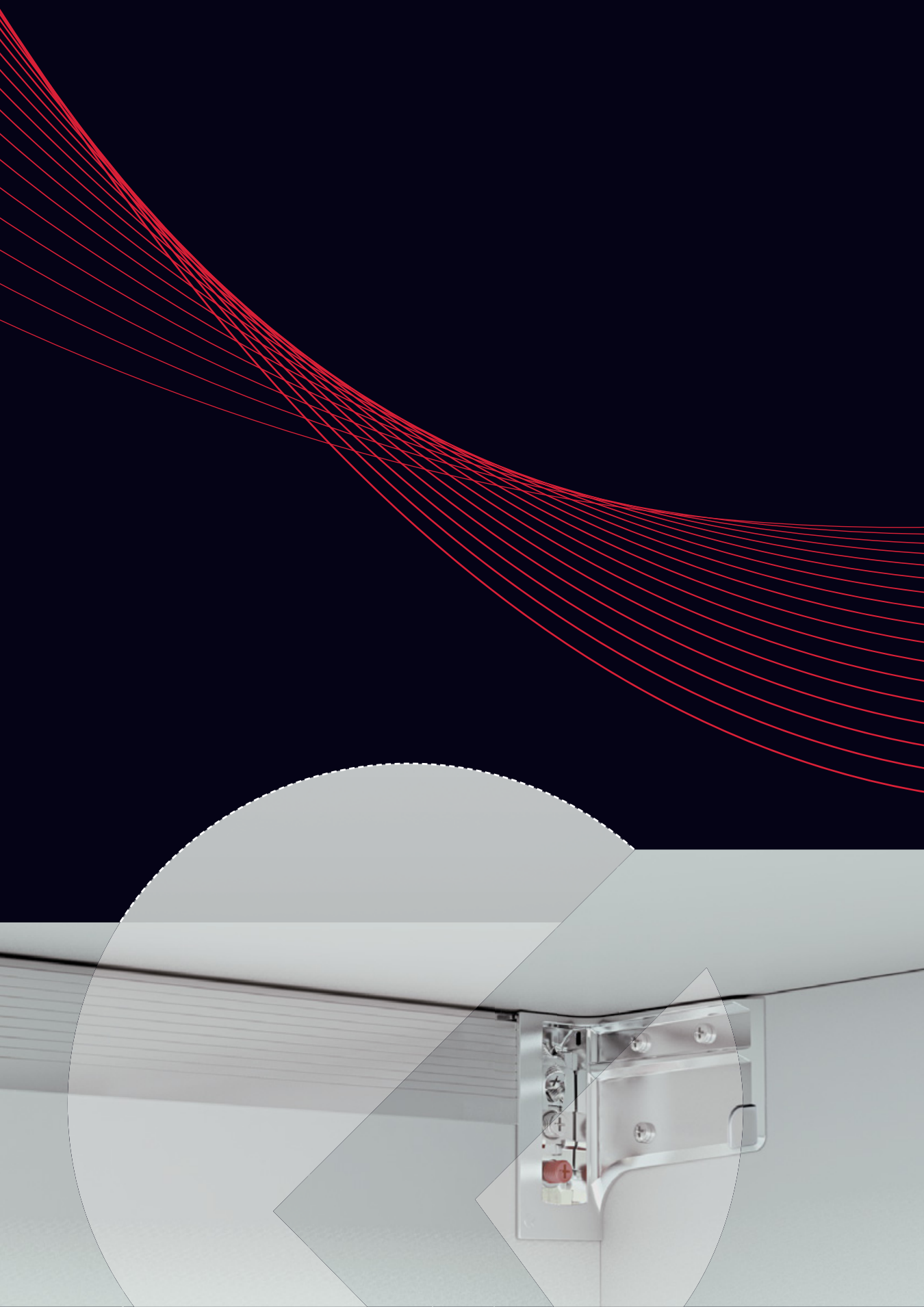

HANGERS





# SYMBOLS AND FINISHES LEGEND

## SYMBOLS

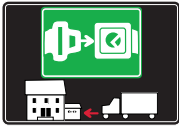

= SHELF SAFELY LOCKED DURING TRANSPORTATION AND AT HOME.



= ANTI-TURNOVER LOCKING SYSTEM



= NORMS / PATENTS



= PHILLIPS / POZIDRIV



= NEWTON



= PART.NO



= HEXAGONAL SOCKET



= FRICTION



= PCS. PER PACKAGE



= BLADE SLOT



= AUTOMATIC



= COMBI SLOT



= DROP DOWN



= CAPACITY LOADING



= COUNTERSUNK HEAD



= WOOD / GLASS THICKNESS



= PAN HEAD



= STANDARD HINGE



= HOLE DIAMETER



= FLANGE HEAD



= KIMANA HINGE



= DIAMETER



= FLAT HEAD



= FLAP HINGE



= LENGTH



= TRILOBULAR SCREW



= WITH SPRING



= HEIGHT



= SELF-TAPPING SCREW



= WITHOUT SPRING



= RIGHT VERSION



= EURO THREAD



= REVERSED SPRING



= LEFT VERSION



= METRIC THREAD



= SETTING CODE



= PRE-INSERTED SCREW



= FOR ROUND TUBE



= PCS. PER PAD



= PRE-INSERTED SCREW AND SPREADING BUSH



= FOR OVAL TUBE



= CUT ON REQUEST



= WITH BUFFER



= SELF ADHESIVE



= WITH MAGNET



= WITH FLANGE

NOTE: Printing errors and omissions may exist despite our best efforts to ensure accuracy. We reserve the right to alter specifications without notice.

## MATERIALS

<b>ZA</b> = Zinc Alloy	<b>ST</b> = Steel	<b>HSS</b> = High Speed Steel	<b>BR</b> = Brass	<b>ABS</b> = Acrylonitrile Butadiene Styrene
<b>ZAnk</b> = Nickel-plated Zinc Alloy	<b>STzk</b> = Zinc-plated Steel	<b>AL</b> = Aluminium	<b>WD</b> = Wood	<b>EVA</b> = Ethylene Vinyl Acetate

**EP** = **ENGINEERING PLASTIC**

+ **EP** = other engineering plastic available on request

**SR** = **SOFT RUBBER**

+ **SR** = other soft rubber available on request

<b>EPn</b> = Natural Engineering Plastic	<b>EPc</b> = Clear Engineering Plastic	<b>SRn</b> = Natural Soft Rubber
<b>EPw</b> = White Engineering Plastic	<b>EPg</b> = Grey Engineering Plastic	<b>SRw</b> = White Soft Rubber
<b>EPwg</b> = Water Green Engineering Plastic		<b>SRb</b> = Black Soft Rubber



## FINISHES



= OTHER FINISHES AVAILABLE ON REQUEST

PART. NO	FINISHES	PART. NO	FINISHES	PART. NO	FINISHES
AA	Natural	JB	Bright Aluminium	QB	Walnut
AB	White	JC	Aluminium - Chrome	RO	Red
AC	Opal White	JD	Matt Aluminium	UZ	T -Met
AE	White 9010	JE	Satin-finished Aluminium	WA	Bronzed
AK	Champagne	JF	Aluminium - Brass	WI	Burnished
AL	Ivory	JG	Aluminium 5	XD	Satin-finished Steel
EA	Black	JL	Aluminium PE 11	YA	Nickel-plated
EB	Glossy Black	JM	Aluminium RAL 9006	YB	Bright Nickel-plated
EC	Matt Black	KA	Chrome	YC	Matt Nickel-plated
EE	Anthracite	KB	Bright Chrome	YD	Satin-finished Nickel-plated
FU	Gunmetal	KC	Matt Chrome	ZA	Zinc alloy
GR	Raw	MA	Brown	ZN	Zinc-plated
HA	Brass-Plated	MB	Light Brown 1	ZQ	Bright Gold
HH	Tropicalized	NN	Metallic Beige	ZY	Titanium
HL	Raw Brass	NO	Beige	ZZ	Clear
IA	Grey	OA	Oak	00	Insignificant finish
IB	Metallic Grey	OZ	Ash		
IF	Middle Grey	PA	Light Ash		
IJ	Light Grey	PZ	Beech		
IL	Grey 20	QA	Maple		

## LIBRA H7 APPLICATIONS: SCREW FIXING and DOWEL FIXING WITH OPTIONAL ALUMINIUM BARS

### BENEFITS OF LIBRA H7 HANGING SYSTEM:

- Vertical and in-depth adjustments as well as the locking of the cabinet, can be easily and smoothly carried out from the inside.
- The hanging system is never interfering with the slides for drawers thanks to the slim side bracket wings.
- Absolutely no mills, nor grooves required on the side panels.

In the **current absence of a unifying European norm** which sets the standards for testing procedures aimed at defining capacity loadings of hanging systems conceived for suspended base units, we Italiana Ferramenta have simulated some of the most critical scenarios. The following simulations are meant to give our customers valid reference points concerning cabinet dimensions, weights, recommended loading capacity even when loaded drawers are opened. **The reported data, empirically obtained, exclusively refer to the constructions and examples shown, correctly positioned and assembled by using WP5 wall plate.**

The customer must ensure that the wall is of suitable quality and structure.

Other important factors to be taken into consideration are determined by:

- the type of side panel, the actual thickness and the material used.
- the type and dimensions of the screws used.
- the actual positioning, depth and width of the groove milled for the back side installation.
- the capacity loading of the drawer slides used as well as the actual construction of the drawer.

We always recommend to test a complete cabinet.

For cases which differ from the ones reported, please contact us.

#### LIBRA H7 SCREW FIXING

#### LIBRA H7 DOWEL FIXING

#### LIBRA WP5

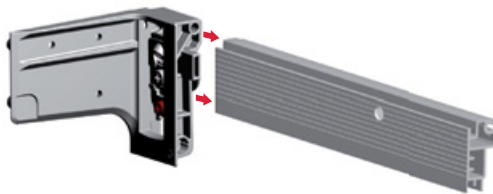

WITH ALU BAR H. 40,2

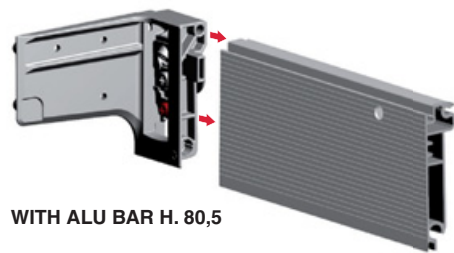

WITH ALU BAR H. 80,5

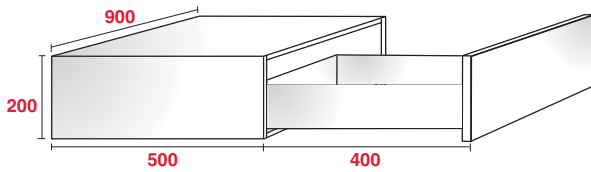

CAPACITY LOADING			
LIBRA H7 AND CABINET WITH STRUCTURAL TOP		FURNITURE TYPE	LIBRA H7 DOWEL FIXING AND ALU BAR H. 40,2 WITH 2 EXTRA HANGING POINTS
SCREW FIXING	DOWEL FIXING		
120 Kg	120 Kg	Cabinet	160 Kg
80 Kg + 30 Kg	80 Kg + 30 Kg	Cabinet + drawer	120 Kg + 30 Kg

The reported data, empirically obtained, exclusively refer to the constructions and examples shown, correctly positioned and assembled by using WP5 wall plate.

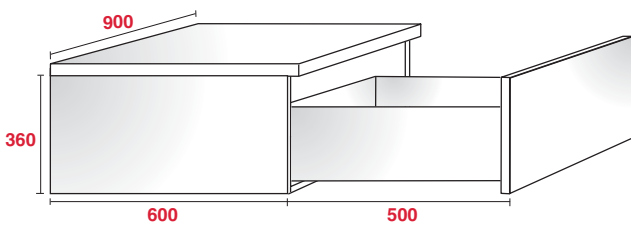

CAPACITY LOADING			
LIBRA H7 AND CABINET WITH STRUCTURAL TOP		FURNITURE TYPE	LIBRA H7 DOWEL FIXING AND ALU BAR H. 40,2 WITH 2 EXTRA HANGING POINTS
SCREW FIXING	DOWEL FIXING		
160 Kg	150 Kg	Cabinet	180 Kg
120 Kg + 30 Kg	110 Kg + 30 Kg	Cabinet + drawer	140 Kg + 30 Kg

The reported data, empirically obtained, exclusively refer to the constructions and examples shown, correctly positioned and assembled by using WP5 wall plate.

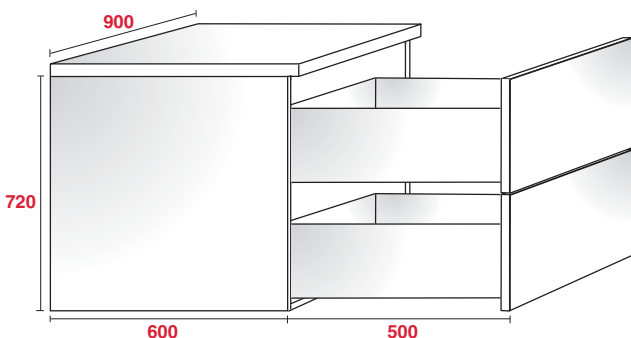

CAPACITY LOADING			
LIBRA H7 AND CABINET WITH STRUCTURAL TOP		FURNITURE TYPE	LIBRA H7 DOWEL FIXING AND ALU BAR H. 40,2 WITH 2 EXTRA HANGING POINTS
SCREW FIXING	DOWEL FIXING		
200 Kg	170 Kg	Cabinet	210 Kg
130 Kg + 60 Kg	100 Kg + 60 Kg	Cabinet + drawer	140 Kg + 2 x 30 Kg

The reported data, empirically obtained, exclusively refer to the constructions and examples shown, correctly positioned and assembled by using WP5 wall plate.

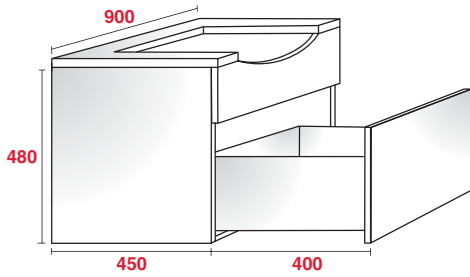

CAPACITY LOADING 			
LIBRA H7 AND CABINET WITH STRUCTURAL TOP		FURNITURE TYPE	LIBRA H7 DOWEL FIXING AND ALU BAR H. 40,2 WITH 2 EXTRA HANGING POINTS
SCREW FIXING	DOWEL FIXING		
200 Kg	170 Kg	Cabinet	210 Kg
160 Kg + 30 Kg	130 Kg + 30 Kg	Cabinet + drawer	170 Kg + 30 Kg

The reported data, empirically obtained, exclusively refer to the constructions and examples shown, correctly positioned and assembled by using WP5 wall plate.

The hanging system is never interfering with the slides for drawers thanks to the slim side bracket wings.

Easy access to the adjustments

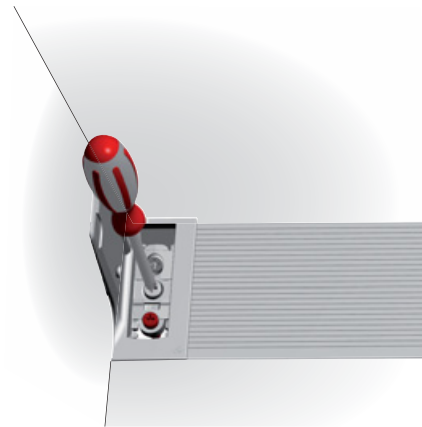
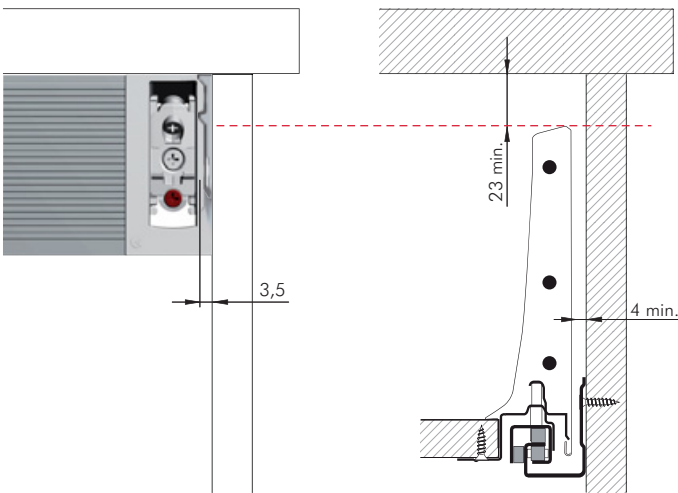

The slim side bracket makes the use of tools very easy and comfortable as there is plenty of space between the side and the screwdriver.

 = STRESS INTENSITY LEVEL ON THE WALL

By adding extra hanging points on the aluminium bar, the capacity loading is more evenly distributed, thus sensibly reducing the stress intensity level on the wall.

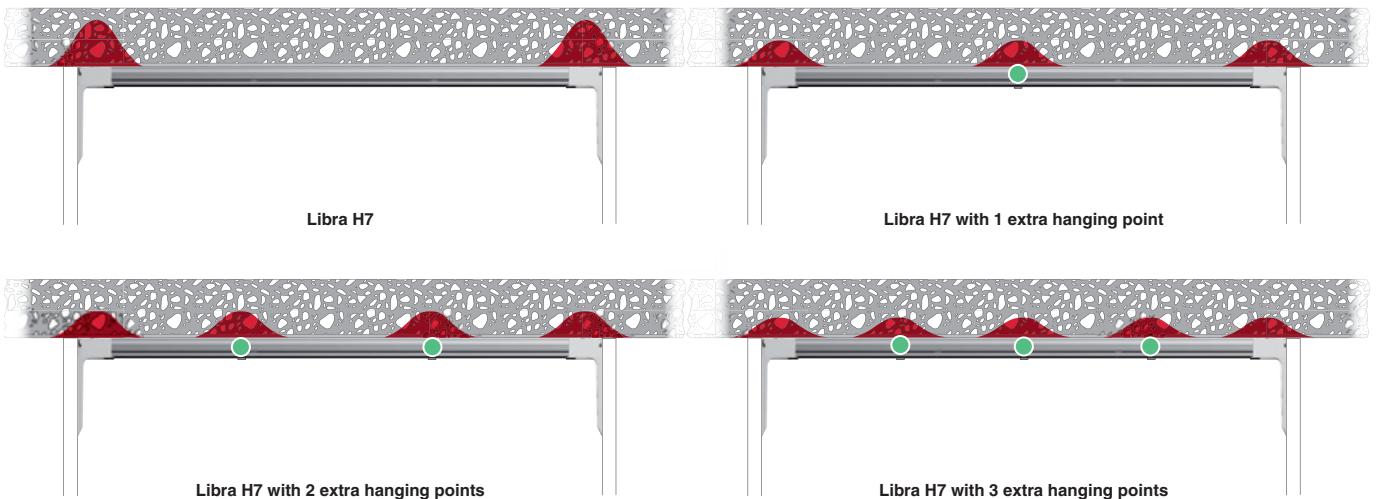

## LIBRA H7 SCREW FIXING LIVING SETTINGS





**LIBRA H7 SCREW FIXING**



INSTALLATION UNDER THE CABINET TOP

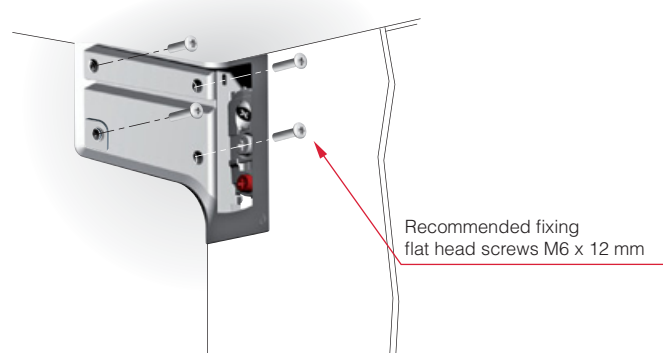
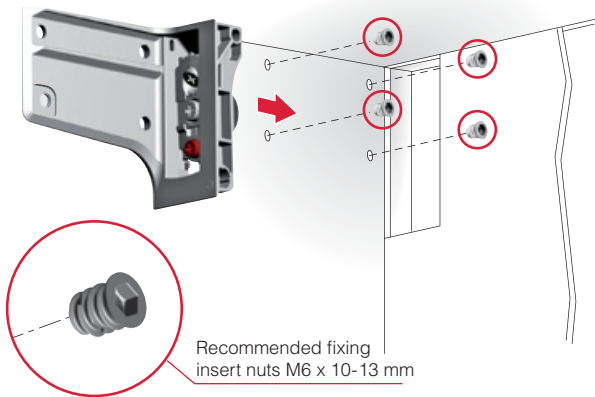

ALTERNATIVE APPLICATION WITHOUT TOP

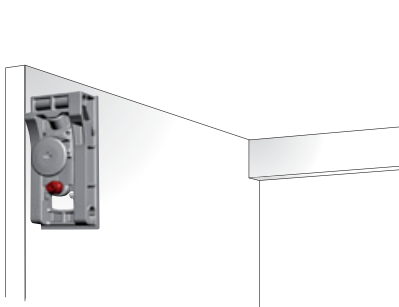

INSTALLATION ON THE WALL

- For details refer to "LIBRA WALL PLATES: LIBRA WP5"

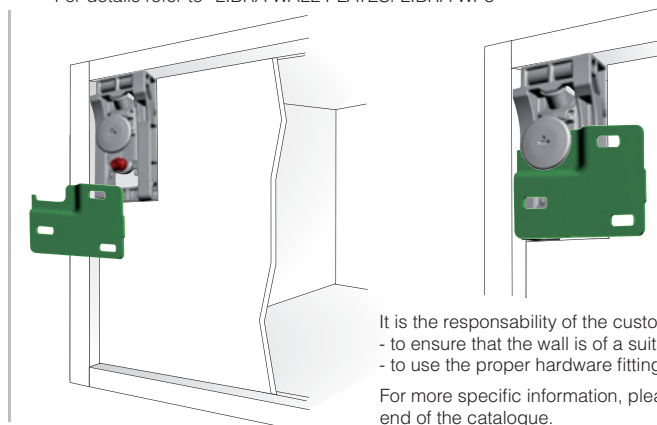

It is the responsibility of the customer:  
 - to ensure that the wall is of a suitable quality to hold the unit fixing in place.  
 - to use the proper hardware fittings according to the construction of the wall.  
 For more specific information, please refer to the WARNINGS section at the end of the catalogue.

ADJUSTMENTS

**1**  
VERTICAL ADJUSTMENT  
13 mm

**2**  
IN-DEPTH ADJUSTMENT  
12 mm

**3**  
ANTI-TURNOVER LOCKING  
Stop screwing the red bolt when it touches the wall plate

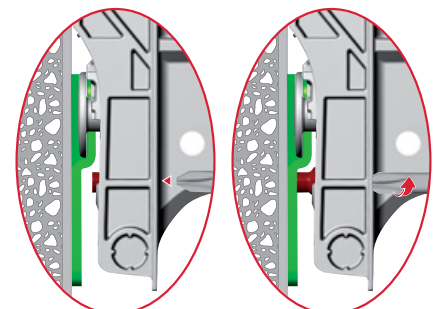
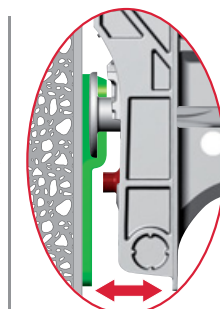
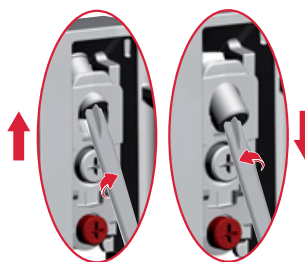
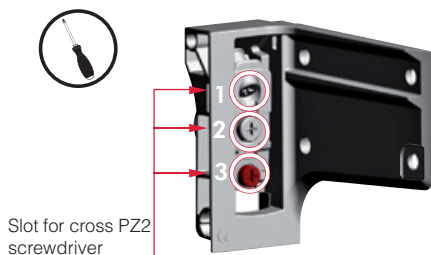

SIDE PANEL 15 - 16 MM THICK

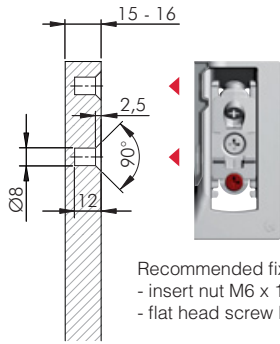

Recommended fixing accessories:  
- insert nut M6 x 10 mm  
- flat head screw M6 x 12 mm

SIDE PANEL 18 - 19 MM THICK

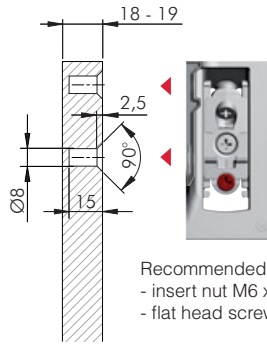

Recommended fixing accessories:  
- insert nut M6 x 13 mm  
- flat head screw M6 x 12 mm

DRILLING PLAN WITHOUT BACK PANEL

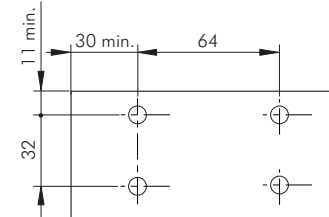

DRILLING PLAN WITH BACK PANEL WOOD THICKNESS 4 - 14 MM

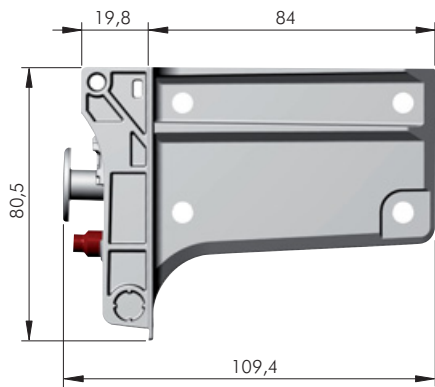
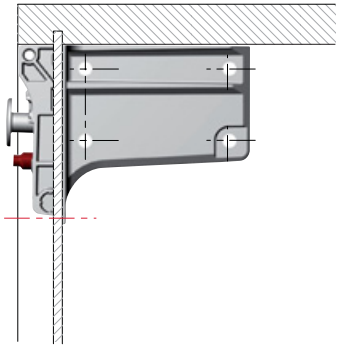
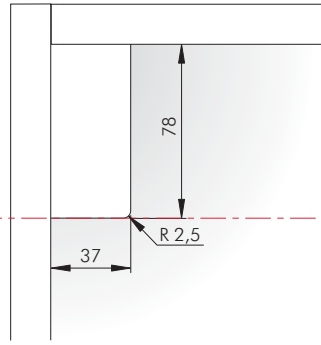
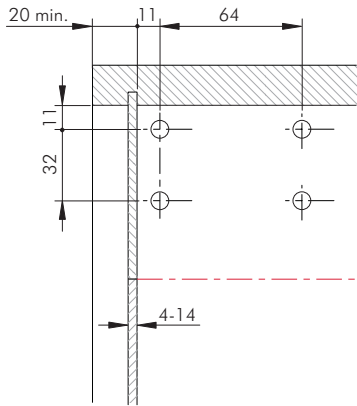

= PZ2

ZA ST

= 50 pcs.



63422260ZN

R

63422270ZN

L





**LIBRA H7 SCREW FIXING ACCESSORIES**

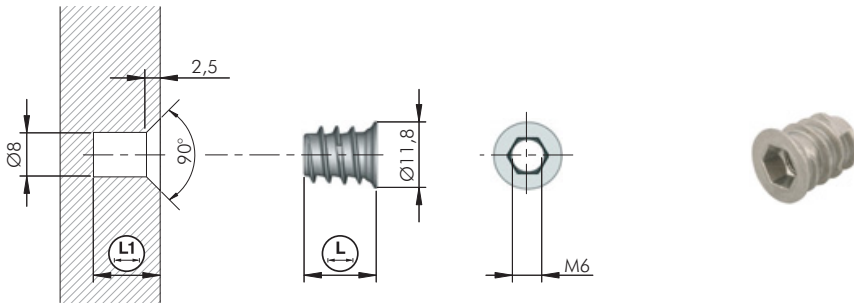

= Ø 8 mm	= M6	+
	= S6	
		= 5000 pcs.
123	= 10	= 12
20102010GR	13	15



= M6	= PZ2	
		= 1000 pcs.
123		
20819020ZN		

**LIBRA H7 DOWEL FIXING WITH ALUMINIUM BAR LIVING SETTINGS**



**LIBRA H7 DOWEL FIXING WITH "PEG JOINT" FOR ALUMINIUM BAR**



PATENTED 

ASSEMBLING WITH OPTIONAL ALUMINIUM BAR H. 40,2 MM OR H. 80,5 MM

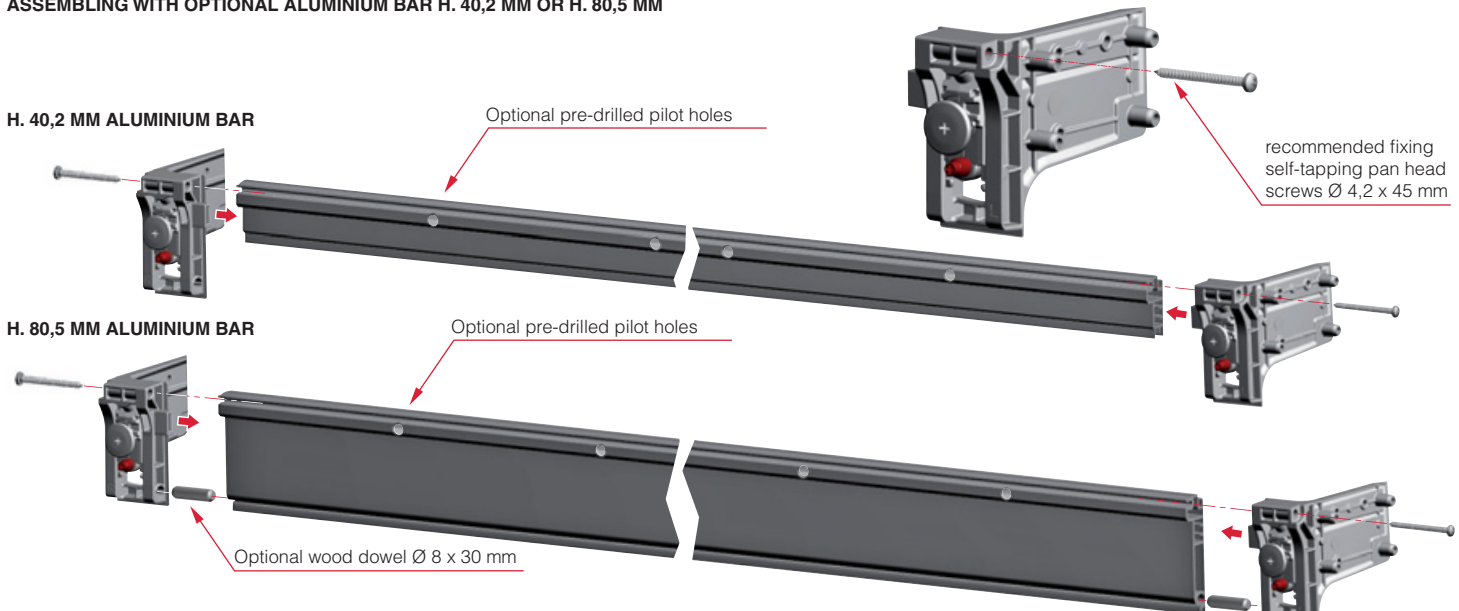

APPLICATION TO THE SUSPENDED BASE CABINET

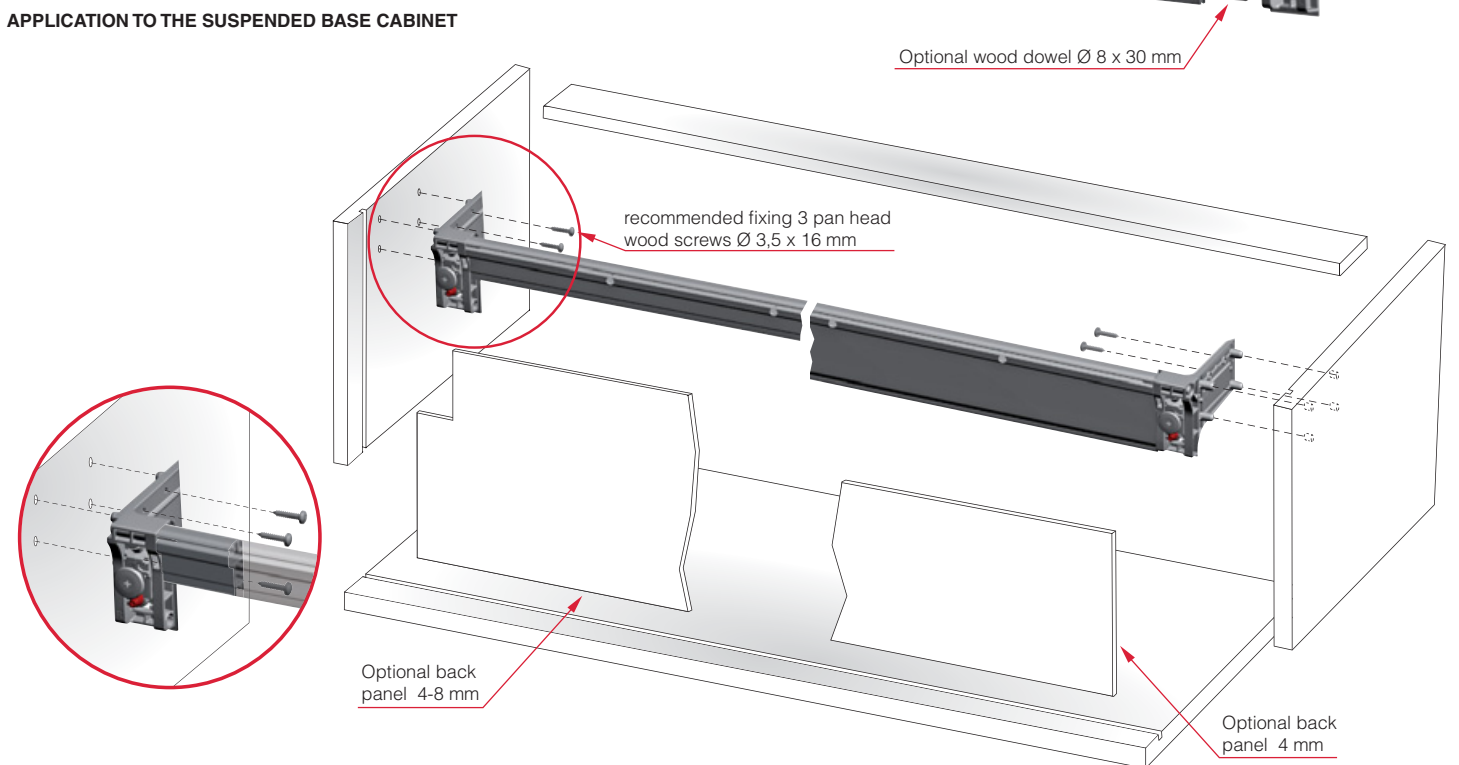

**INSTALLATION ON THE WALL**

- For details refer to "LIBRA WALL PLATES: LIBRA WP5"

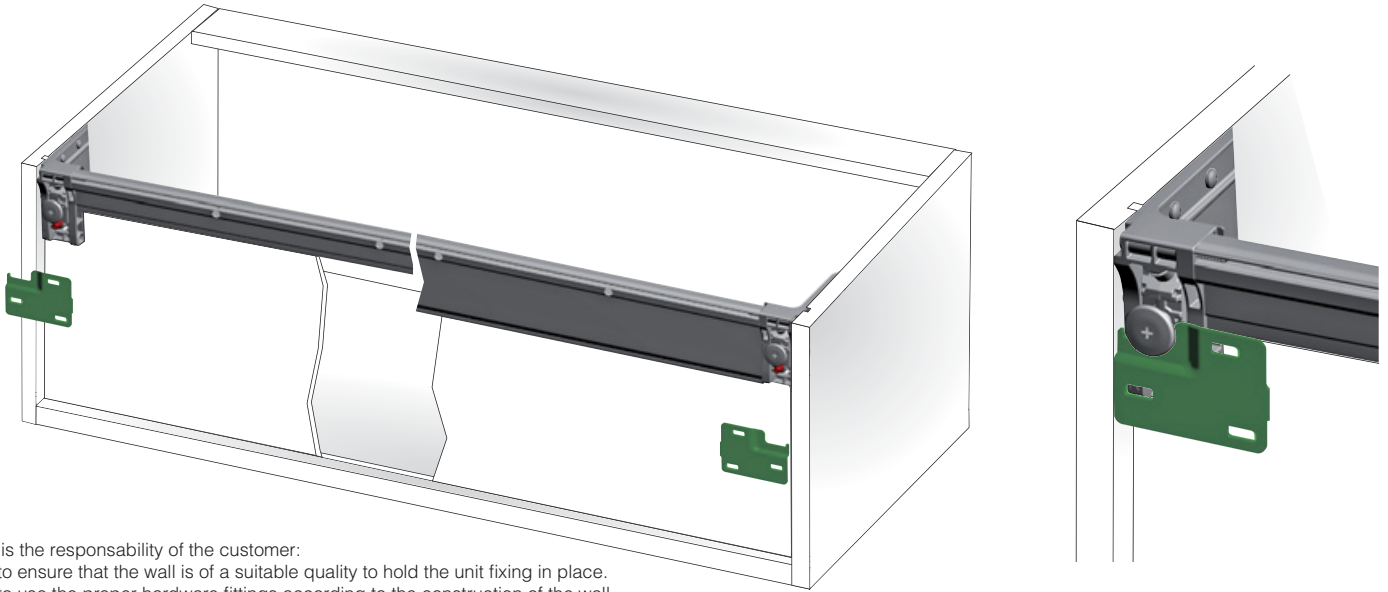

It is the responsibility of the customer:

- to ensure that the wall is of a suitable quality to hold the unit fixing in place.
- to use the proper hardware fittings according to the construction of the wall.

For more specific information, please refer to the WARNINGS section at the end of the catalogue.

**ADJUSTMENTS (STEP 1)**

**1**  
VERTICAL ADJUSTMENT  
13 mm

**2**  
IN-DEPTH ADJUSTMENT  
12 mm

**3**  
ANTI-TURNOVER LOCKING  
Stop screwing the red bolt when it touches the wall plate

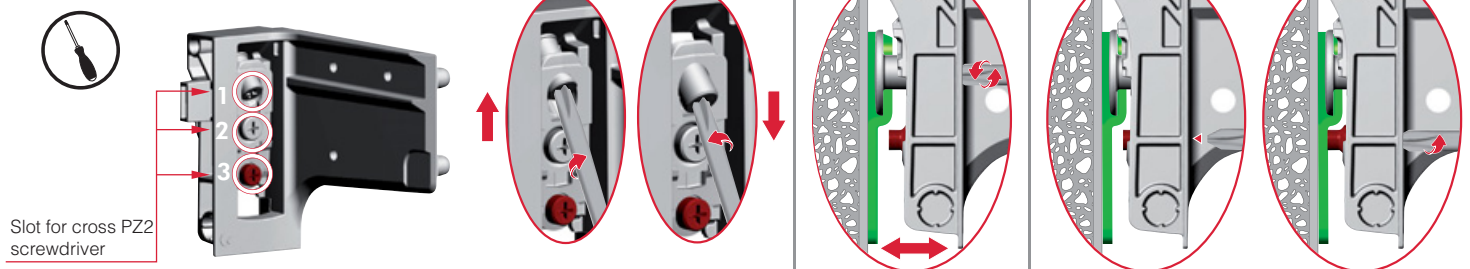
**EXTRA HANGING POINTS (STEP 2)**

The pre-drilled pilot holes ease the drilling operations on the wall.  
Extra hanging points reduce the loading stress on the left/right wall plates.

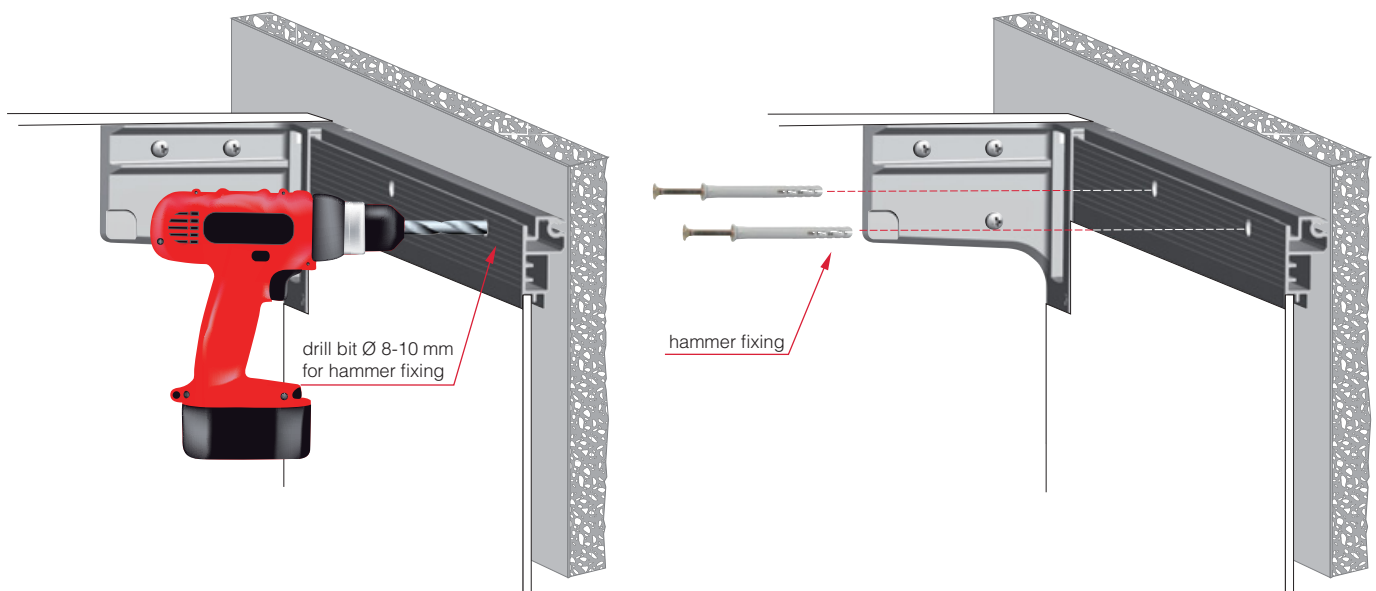



**SIDE PANEL 15 MIN**

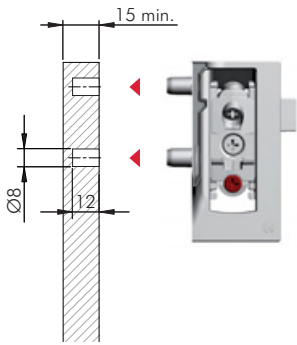

**DRILLING PLAN WITHOUT BACK PANEL**

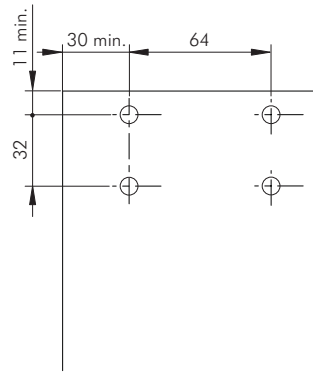

**DRILLING PLAN WITH BACK PANEL WOOD THICKNESS 4 MM**

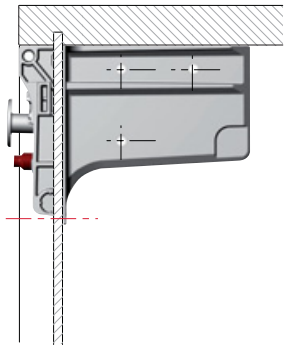
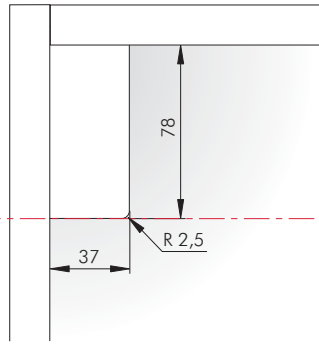
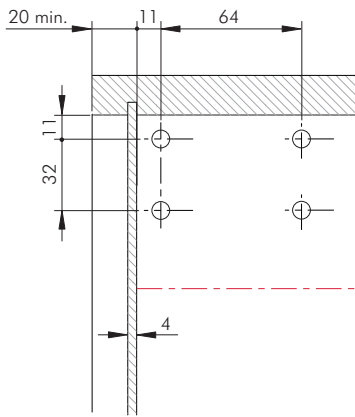

**DRILLING PLAN WITH BACK PANEL WOOD THICKNESS 4 MM AND H. 40,2 MM ALUMINIUM BAR**

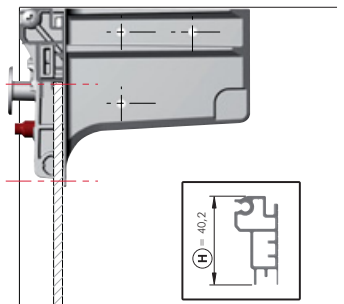
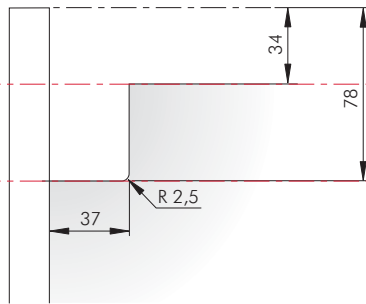
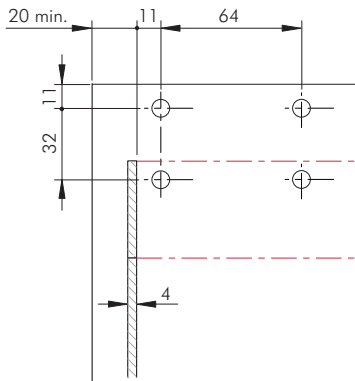

**DRILLING PLAN WITH BACK PANEL WOOD THICKNESS 8 MM AND H. 40,2 MM ALUMINIUM BAR**

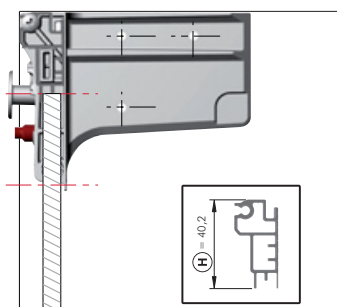
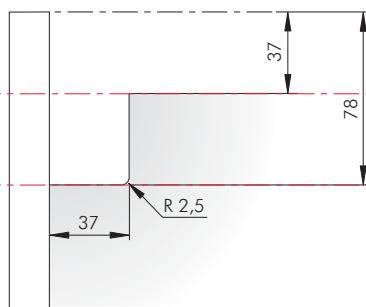
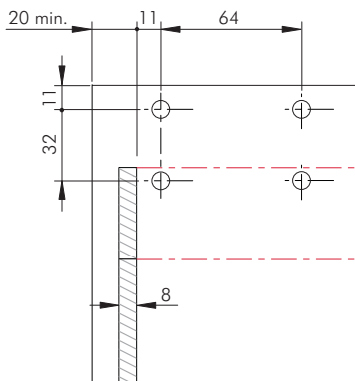

DRILLING PLAN WITH BACK PANEL WOOD THICKNESS 4 MM AND H. 80,5 MM ALUMINIUM BAR

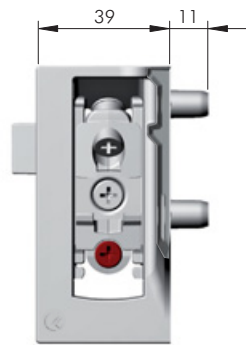
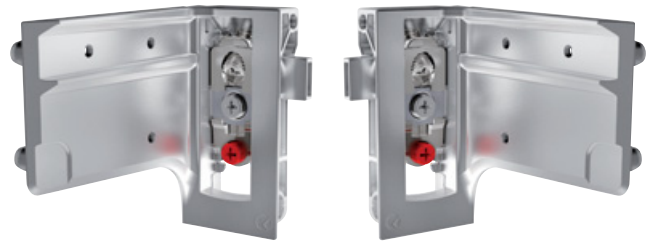
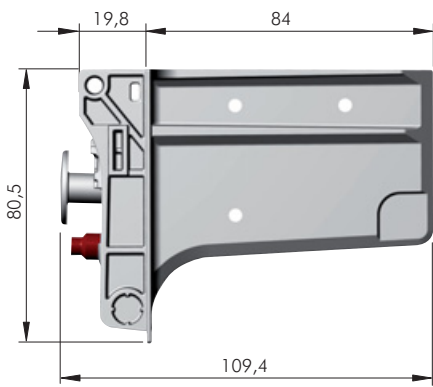
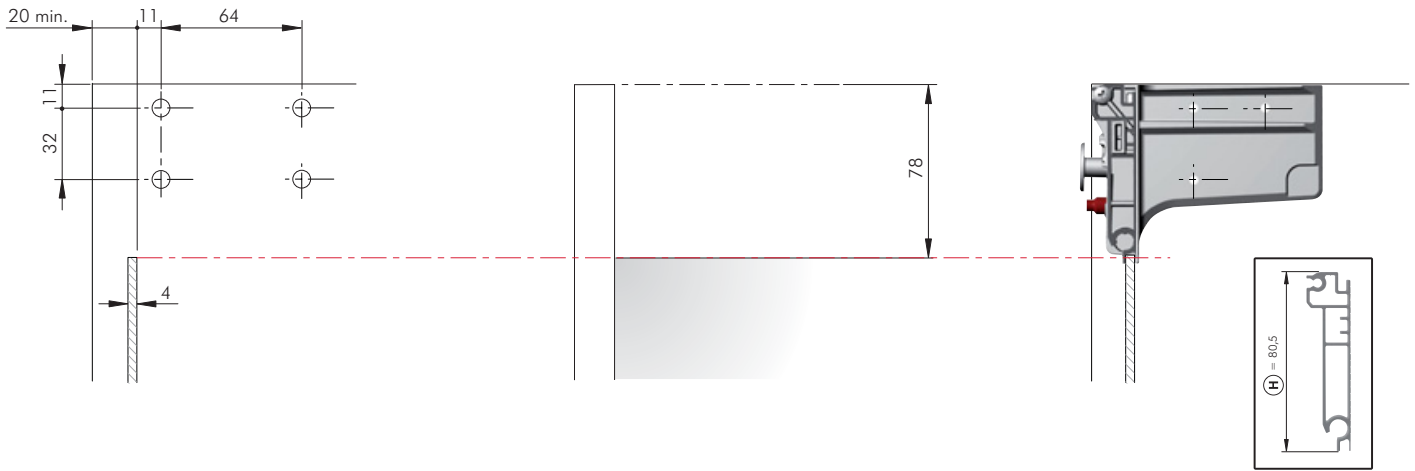

	= PZ2	
		= 50 pcs.
63422200Z		
63422210Z		



**LIBRA H7 ALUMINIUM BAR H. 40,2**

TO BE CUT BY THE CUSTOMER

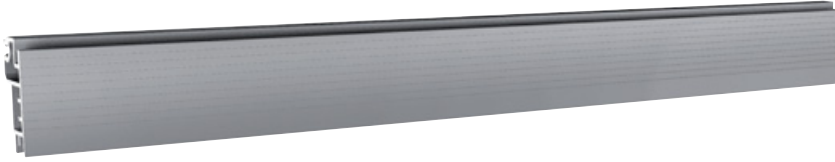

AL	= on request		
123 6700000000	40,2	4000	

Optional pre-drilling operation/s to be carried out by the customer.

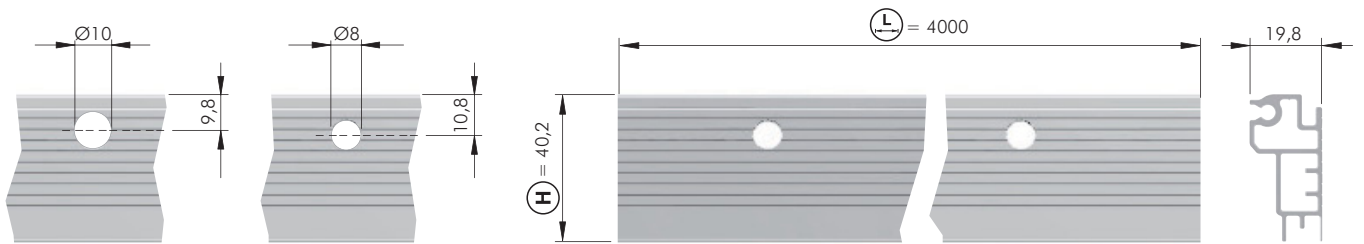

**LIBRA H7 ALUMINIUM BAR H. 80,5**

TO BE CUT BY THE CUSTOMER

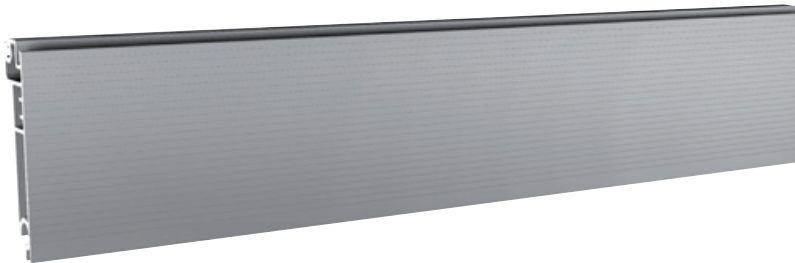

AL	= on request		
123 6710000000	80,5	4000	

Optional pre-drilling operation/s to be carried out by the customer.

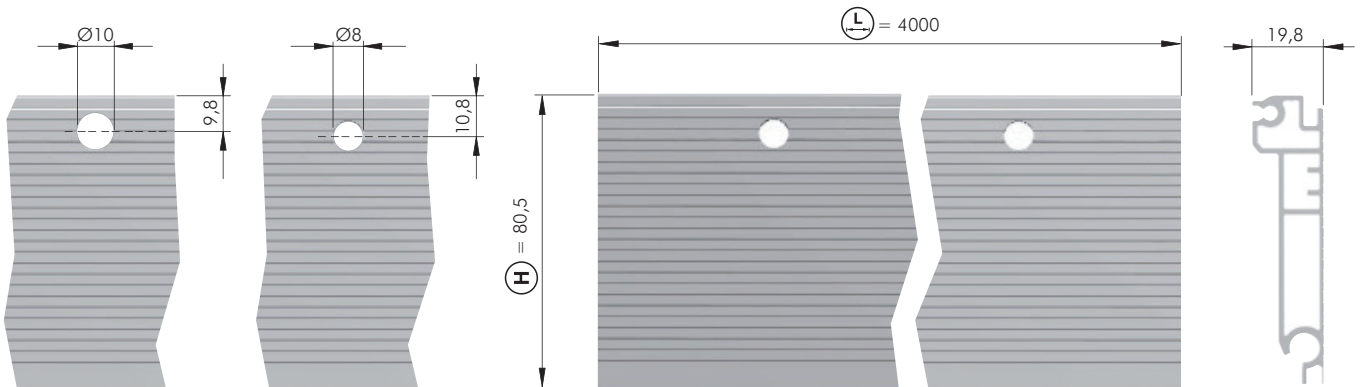

## LIBRA H7 ALUMINIUM BAR H. 40,2 AND H. 80,5 WITHOUT END ELEMENTS

TO BE CUT BY THE CUSTOMER

SUGGESTED POSITIONING OF PRE-DRILLED Ø 8 OR Ø 10 INTERMEDIATE PILOT HOLES ACCORDING TO CABINET WIDTH

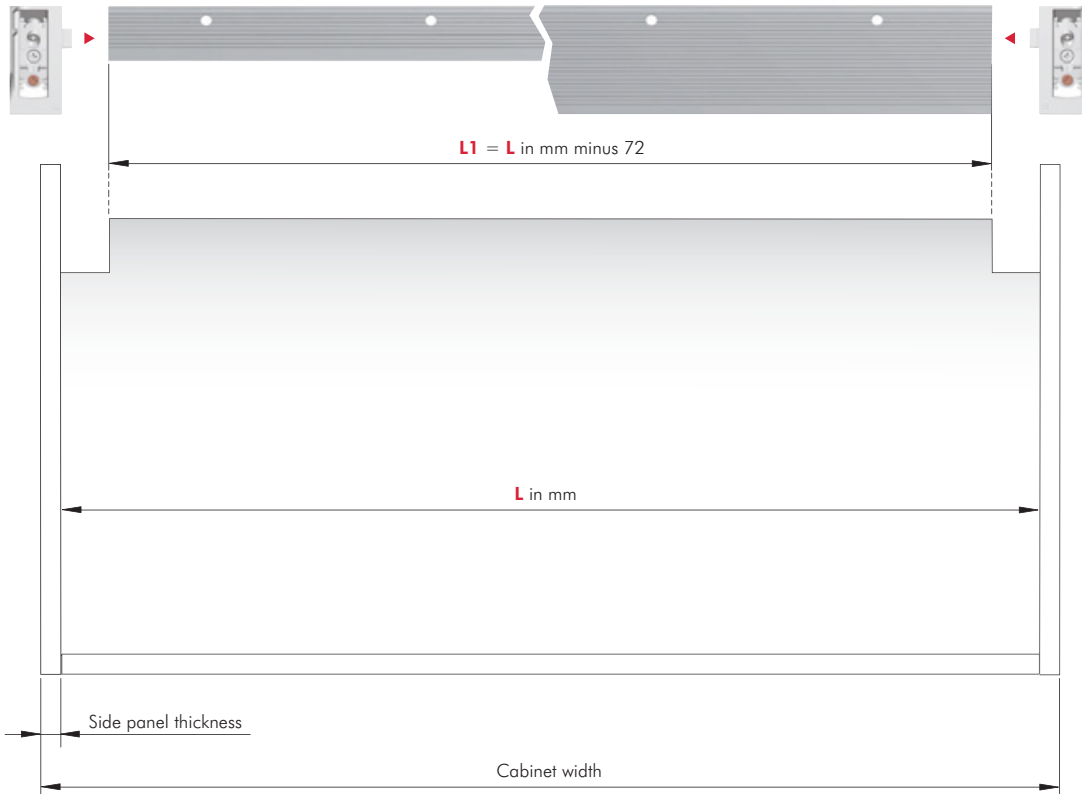

**SUGGESTED COMBINATIONS:**

CABINET WIDTH (mm)	INTERMEDIATE PILOT HOLES
up to 450	-
from 451 to 600	1
from 601 to 950	2
from 951 to 1200	3
over 1201	4

**Cabinet width over 1201**

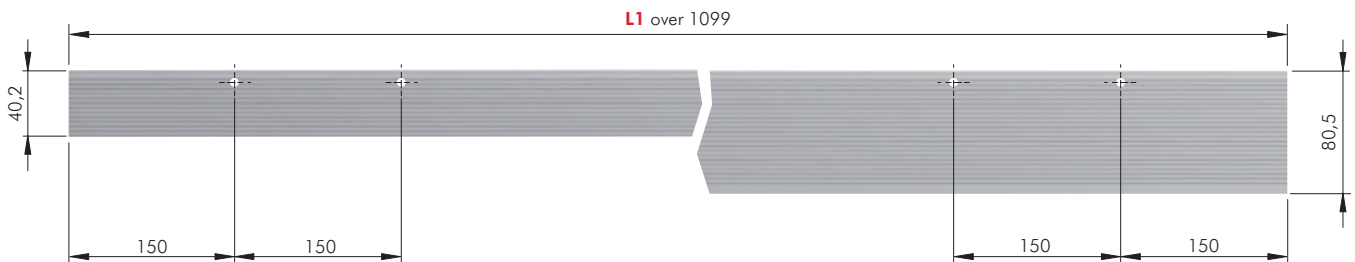

**CABINET WIDTH OVER 1201**

SIDE PANEL	L1
15	1099
16	1097
18	1093
19	1091





**Cabinet width from 951 to 1200**

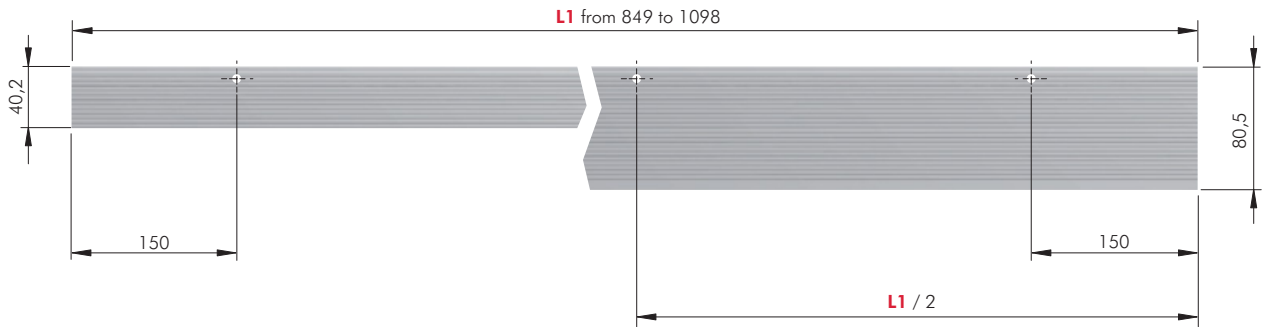

**CABINET WIDTH FROM 951 TO 1200**

SIDE PANEL	FROM - TO
15	849 - 1098
16	847 - 1096
18	843 - 1092
19	841 - 1090

**Cabinet width from 601 to 950**

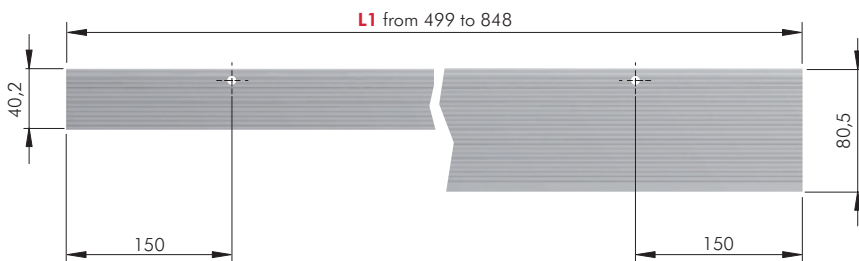

**CABINET WIDTH FROM 601 TO 950**

SIDE PANEL	FROM - TO
15	499 - 848
16	497 - 846
18	493 - 842
19	491 - 840

**Cabinet width from 451 to 600**

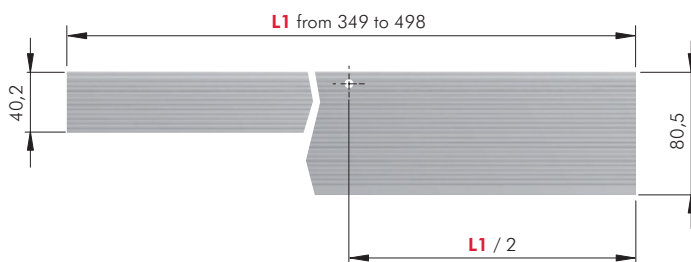

**CABINET WIDTH FROM 451 TO 600**

SIDE PANEL	FROM - TO
15	349 - 498
16	347 - 496
18	343 - 492
19	341 - 490

**Cabinet width 450**

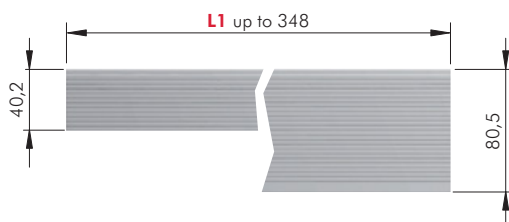

**CABINET WIDTH 450**

SIDE PANEL	L1
15	348
16	346
18	342
19	340

**LIBRA H7 ALUMINIUM BAR H. 40,2 WITHOUT END ELEMENTS:  
CUT ON SIZE WITH PRE-DRILLED Ø 8 INTERMEDIATE PILOT HOLES**

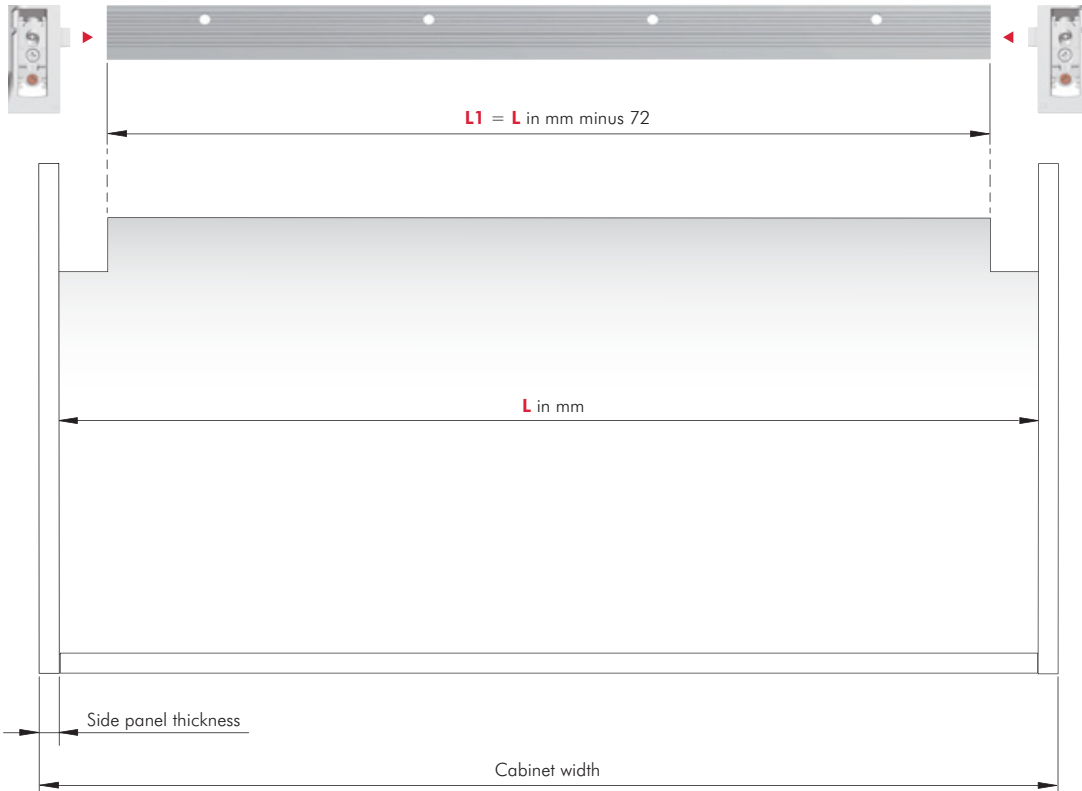

**670XXXXY00**

- 0 = without intermediate pilot hole
- 1 = with 1 intermediate pilot hole
- 2 = with 2 intermediate pilot holes
- 3 = with 3 intermediate pilot holes
- 4 = with 4 intermediate pilot holes

**SUGGESTED COMBINATIONS:**

CABINET WIDTH (mm)	INTERMEDIATE PILOT HOLES
up to 450	-
from 451 to 600	1
from 601 to 950	2
from 951 to 1200	3
over 1201	4

**LIBRA H7 ALUMINIUM BAR H. 80,5 WITHOUT END ELEMENTS:  
CUT ON SIZE WITH PRE-DRILLED Ø 8 INTERMEDIATE PILOT HOLES**

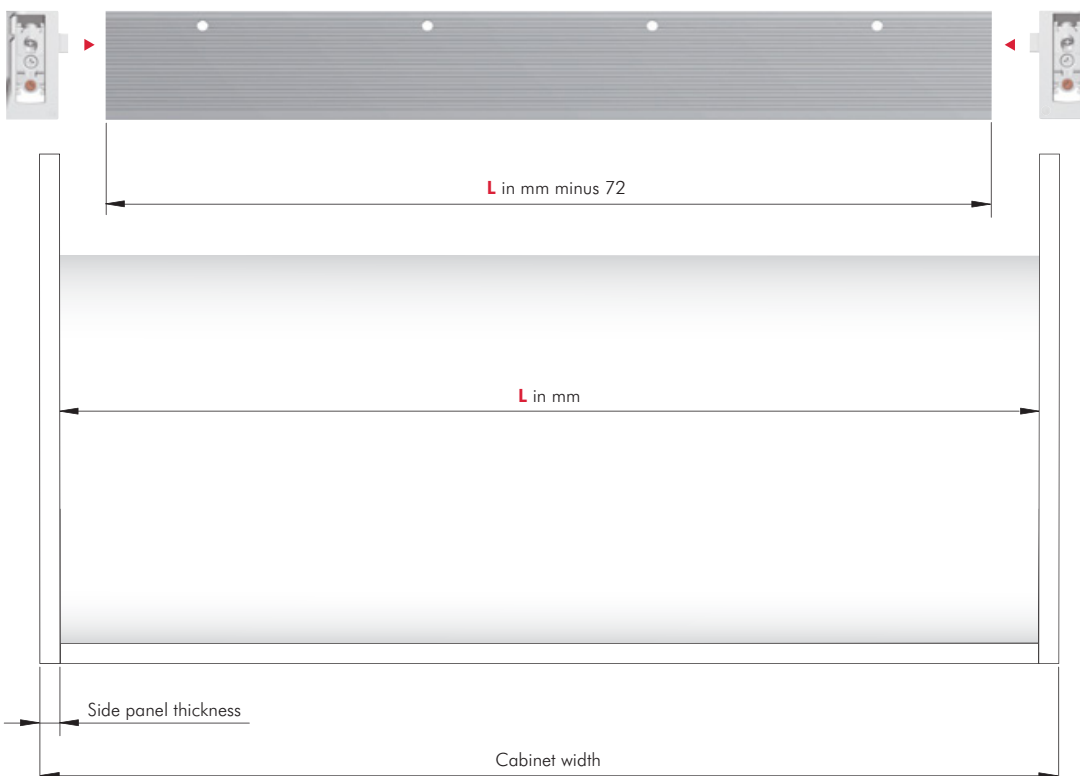

**671XXXXY00**

- 0 = without intermediate pilot hole
- 1 = with 1 intermediate pilot hole
- 2 = with 2 intermediate pilot holes
- 3 = with 3 intermediate pilot holes
- 4 = with 4 intermediate pilot holes

**SUGGESTED COMBINATIONS:**

CABINET WIDTH (mm)	INTERMEDIATE PILOT HOLES
up to 450	-
from 451 to 600	1
from 601 to 950	2
from 951 to 1200	3
over 1201	4



**LIBRA H7 DOWEL FIXING ACCESSORY**

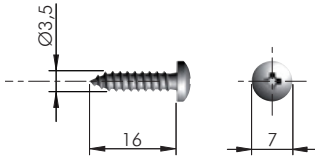

		= PZ2		
ST		= 8000 pcs.		
		60103140ZN		

**LIBRA H7 H. 40,2 AND H. 80,5 ALUMINIUM BAR FIXING ACCESSORY**

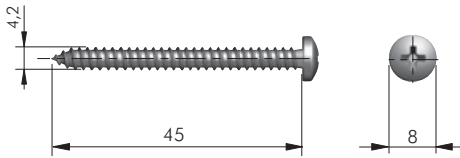

		= PZ2		
ST		= on request		
		60203540ZN		

**LIBRA H7 H. 80,5 ALUMINIUM BAR FIXING ACCESSORY**

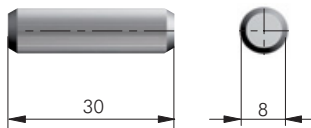

WD		= on request		
		6110001000		

SPACERS FOR LIBRA H7 ALUMINIUM BAR H. 80,5

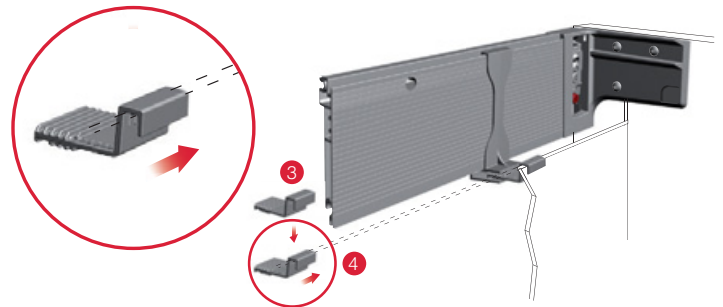
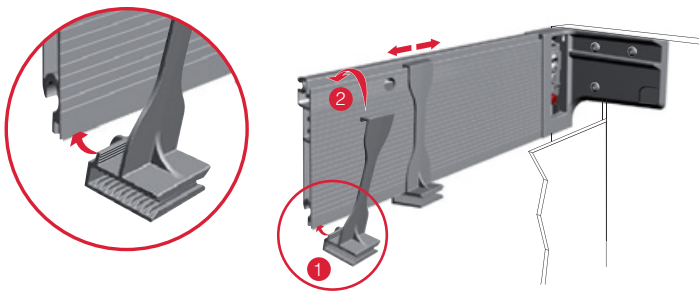

SPACER K

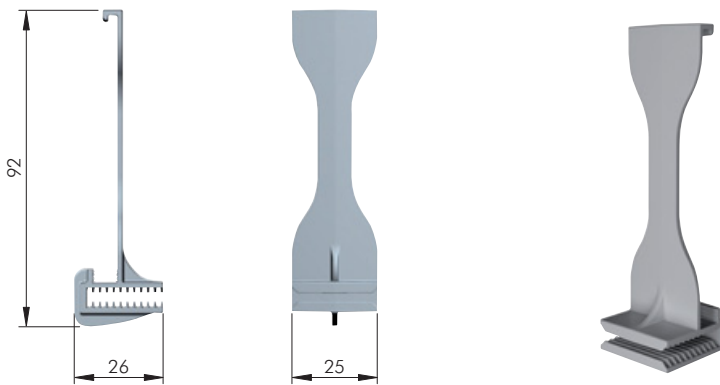

SPACER K36, 36-50 mm

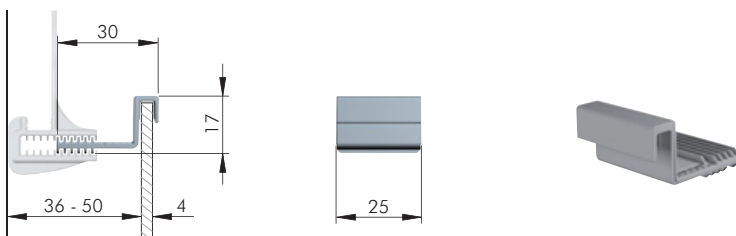

SPACER K47, 47-71 mm

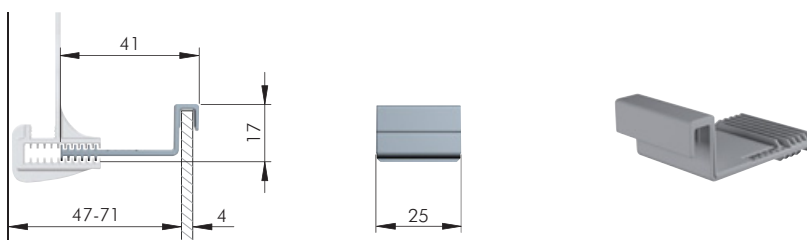



**OPTIONAL VERSION**

**LIBRA H7 SCREW FIXING WITH "PEG JOINT" FOR ALUMINIUM BAR**

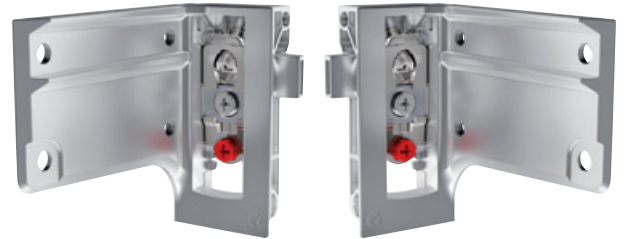
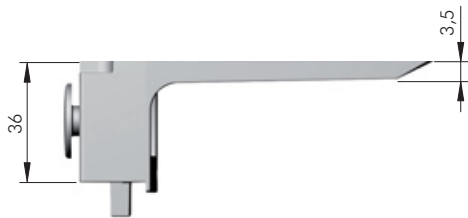
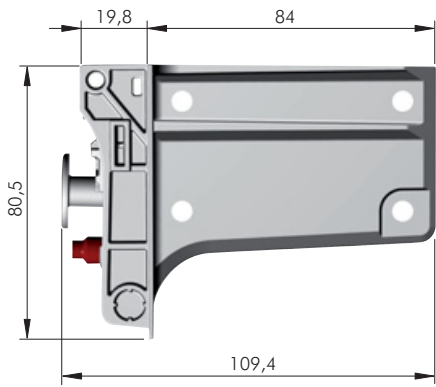

	= PZ2			= 50 pcs.
	63422240ZN			
	63422250ZN			

**SIDE PANEL 15 - 16 MM THICK**

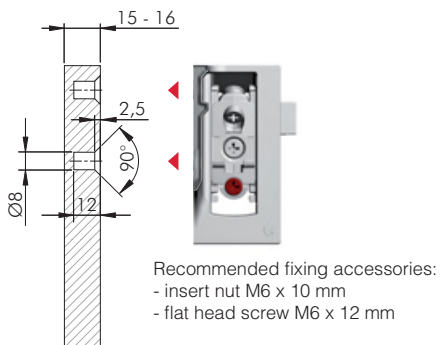

**SIDE PANEL 18 - 19 MM THICK**

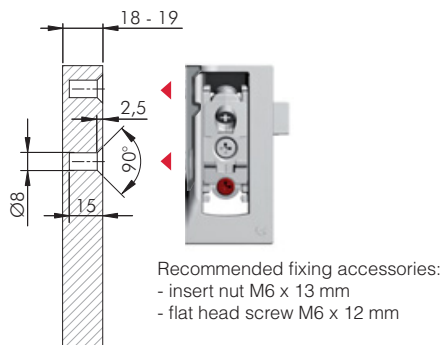

**DRILLING PLAN WITHOUT BACK PANEL**

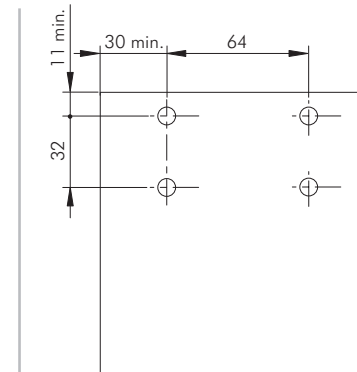

**DRILLING PLAN WITH BACK PANEL WOOD THICKNESS 4 MM**

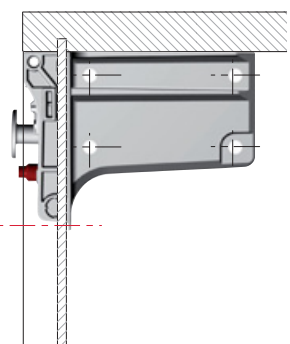
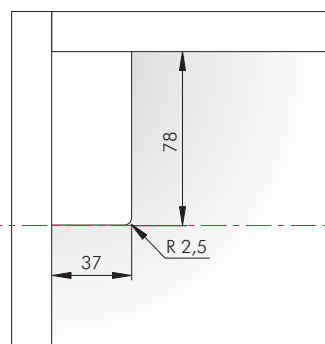
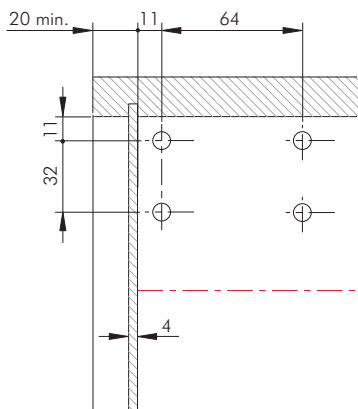

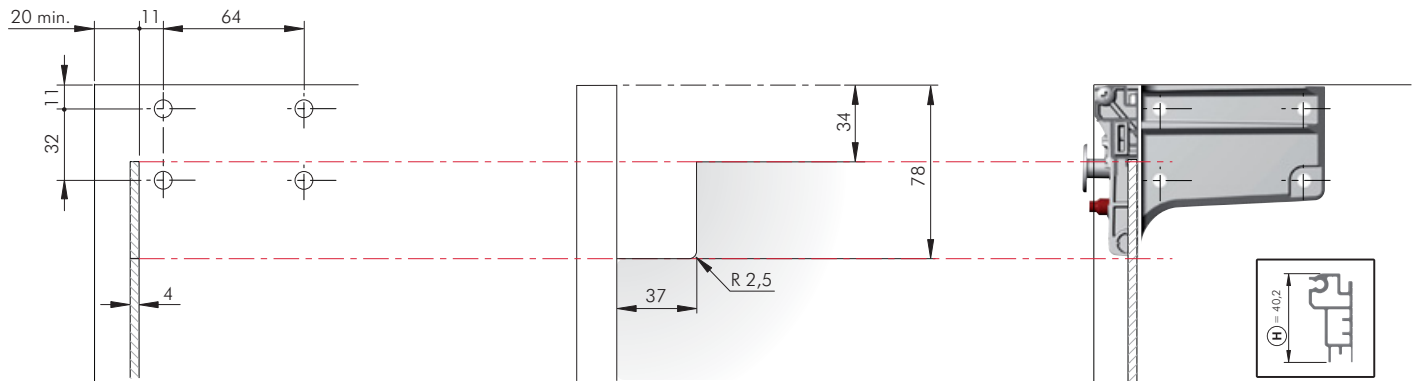
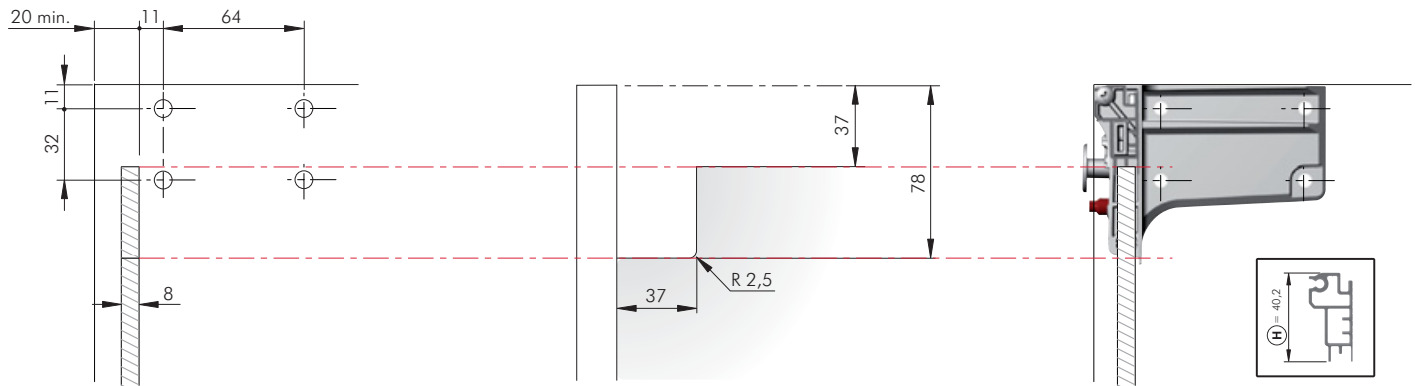
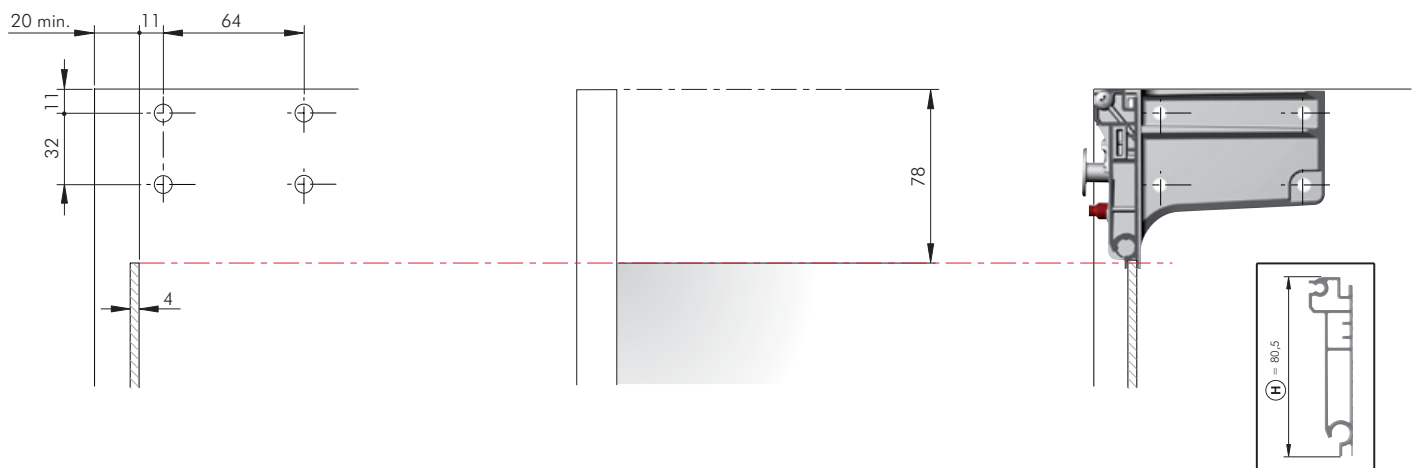
**DRILLING PLAN WITH BACK PANEL WOOD THICKNESS 4 MM AND H. 40,2 MM ALUMINIUM BAR**

**DRILLING PLAN WITH BACK PANEL WOOD THICKNESS 8 MM AND H. 40,2 MM ALUMINIUM BAR**

**DRILLING PLAN WITH BACK PANEL WOOD THICKNESS 4 MM AND H. 80,5 MM ALUMINIUM BAR**

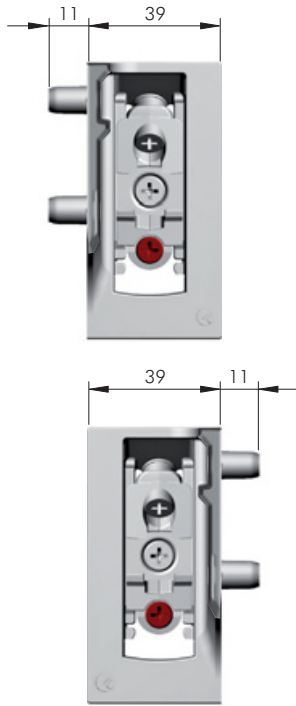
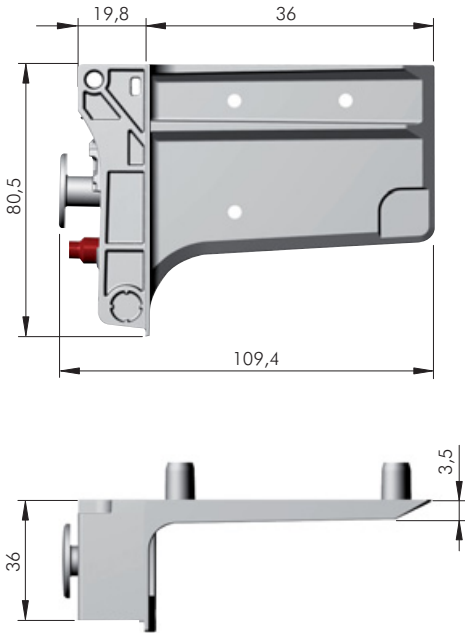

**OPTIONAL VERSION**

**LIBRA H7 DOWEL FIXING WITHOUT "PEG JOINT"**



= PZ2			= 50 pcs.
63422220ZN			
63422230ZN			

**SIDE PANEL 15 MIN**

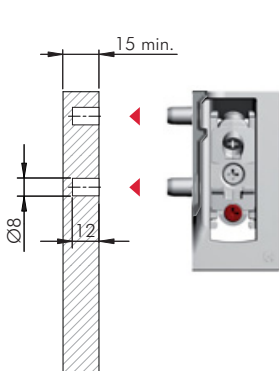

**DRILLING PLAN WITHOUT BACK PANEL**

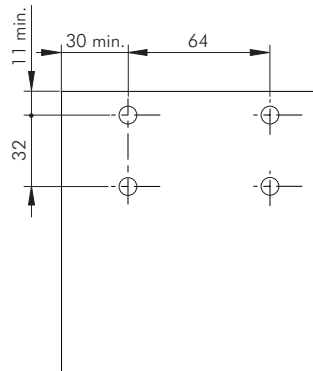

**DRILLING PLAN WITH BACK PANEL WOOD THICKNESS 4 - 14 MM**

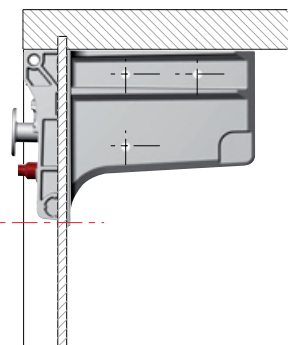
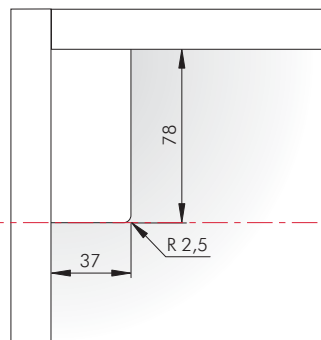
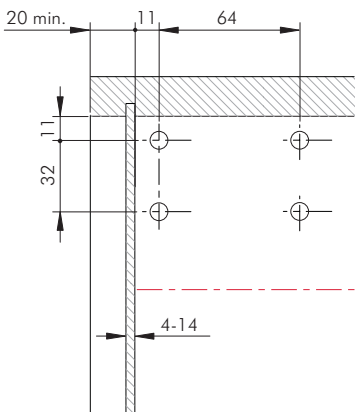

## LIBRA H7 and LIBRA CH LIVING SETTINGS



LIBRA H7



LIBRA CH





## LIBRA H7 and LIBRA CH APPLICATIONS

### BENEFITS OF LIBRA H7 AND LIBRA CH HANGING SYSTEMS:

- Vertical and in-depth adjustments, as well as the locking of the cabinet, can be easily and smoothly carried out from the inside.
- The hanging system is never interfering with the slides for drawers as it is placed behind the back panel.
- Absolutely no mills or grooves required on the side panels.

In the **current absence of a unifying European norm** which sets the standards for testing procedures aimed at defining capacity loadings of hanging systems conceived for suspended base units, we Italiana Ferramenta have simulated some of the most critical scenarios. The following simulations are meant to give our customers valid reference points concerning cabinet dimensions, weights, recommended loading capacity even when loaded drawers are opened.

**The reported data, empirically obtained, exclusively refer to the constructions and examples shown, correctly positioned and assembled by using WP5 wall plate.**

The customer must ensure that the wall is of suitable quality and structure.

Other important factors to be taken into consideration are determined by:

- the type of side panel, the actual thickness and the material used concerning the screw fixing.
- the type and dimensions of the screws used.
- the actual positioning, depth and width of the groove milled for the back side installation.
- the capacity loading of the drawer slides used as well as the actual construction of the drawer.

We always recommend to test a complete cabinet.

**For cases which differ from the ones reported, please contact us.**

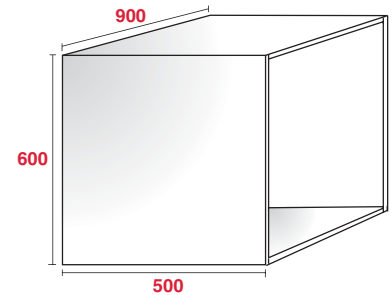
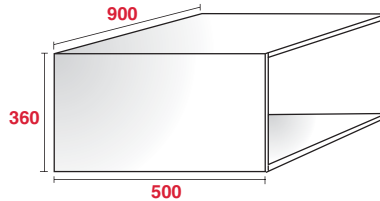
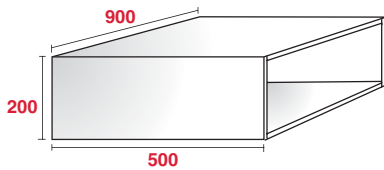

FURNITURE TYPE	CAPACITY LOADING 	
	LIBRA H7	LIBRA H7 + 1 LIBRA CH
Cabinet	120 Kg	130 Kg
Cabinet + drawer	80 Kg + 30 Kg	120 Kg + 30 Kg

FURNITURE TYPE	CAPACITY LOADING 	
	LIBRA H7	LIBRA H7 + 1 LIBRA CH
Cabinet	180 Kg	230 Kg
Cabinet + drawer	150 Kg + 30 Kg	180 Kg + 30 Kg

FURNITURE TYPE	CAPACITY LOADING 	
	LIBRA H7	LIBRA H7 + 1 LIBRA CH
Cabinet	200 Kg	230 Kg
Cabinet + drawer	170 Kg + 30 Kg	170 Kg + 50 Kg

The reported data, empirically obtained, exclusively refer to the constructions and examples shown, correctly positioned and assembled by using WP5 wall plate.

LIBRA H7

LIBRA CH

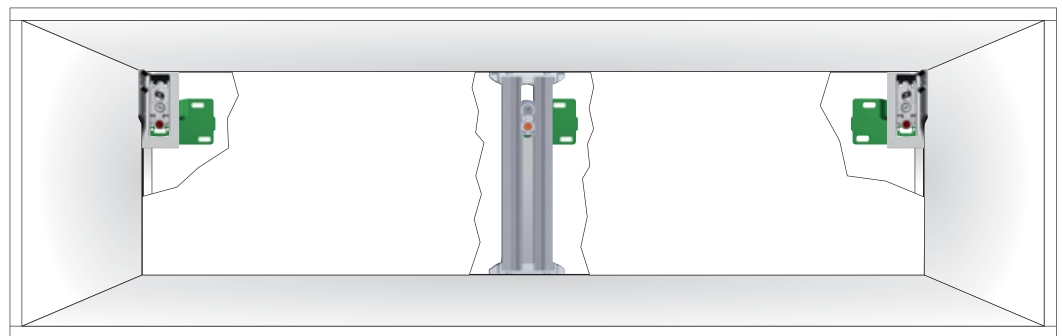

 = STRESS INTENSITY LEVEL ON THE WALL

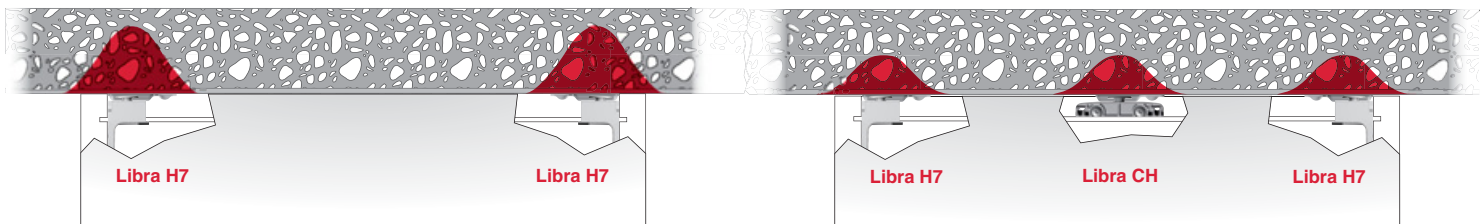

For details refer to sections:

- LIBRA H7 SCREW FIXING (to be used without aluminium bar)
- LIBRA H7 DOWEL FIXING (to be used without aluminium bar).
- LIBRA CH

By adding Libra CH to Libra H7, the capacity loading is more evenly distributed, thus sensibly reducing the stress intensity level on the wall.

DEMONSTRATION SCHEME : WHERE AND HOW TO USE LIBRA H7 AND LIBRA CH

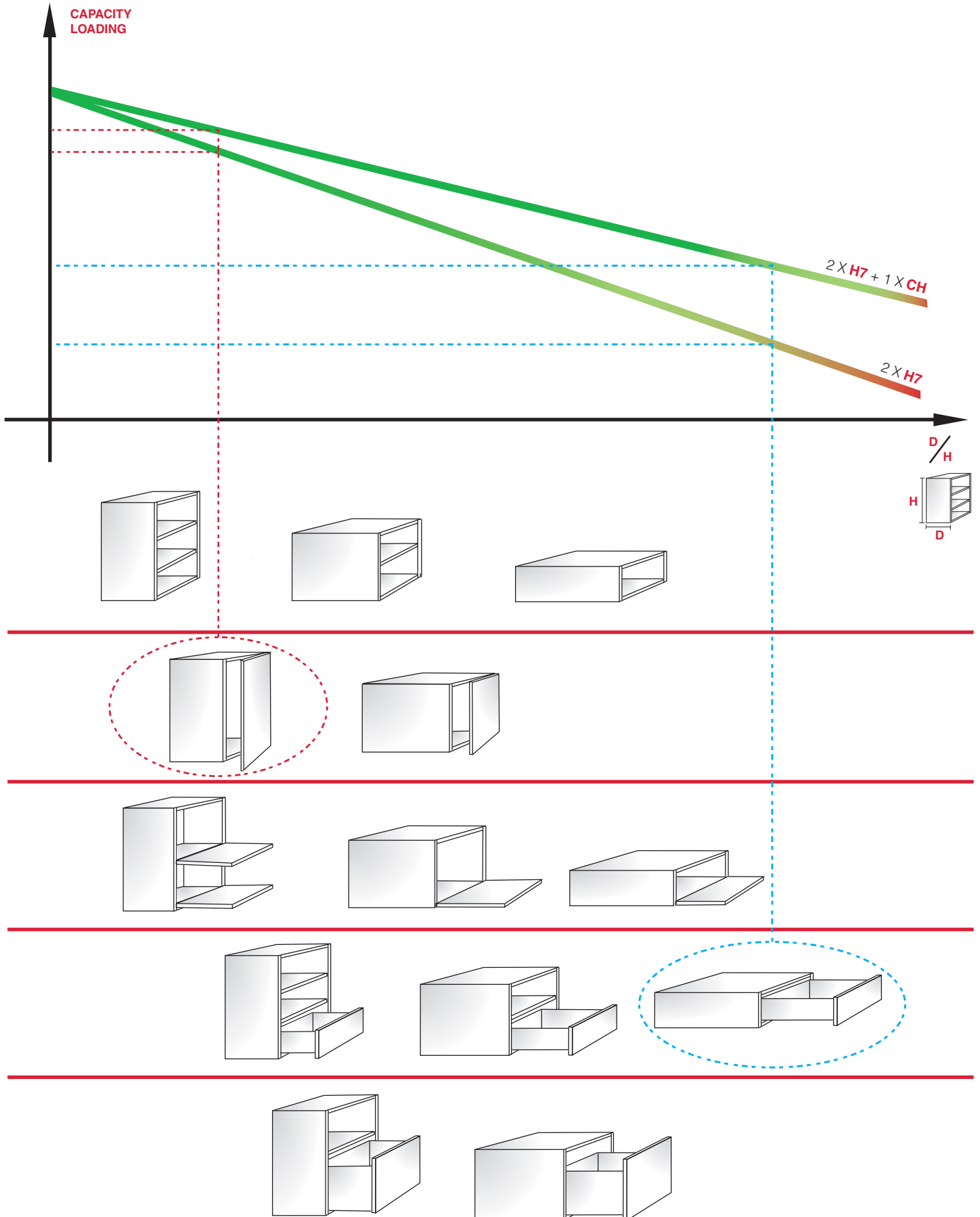

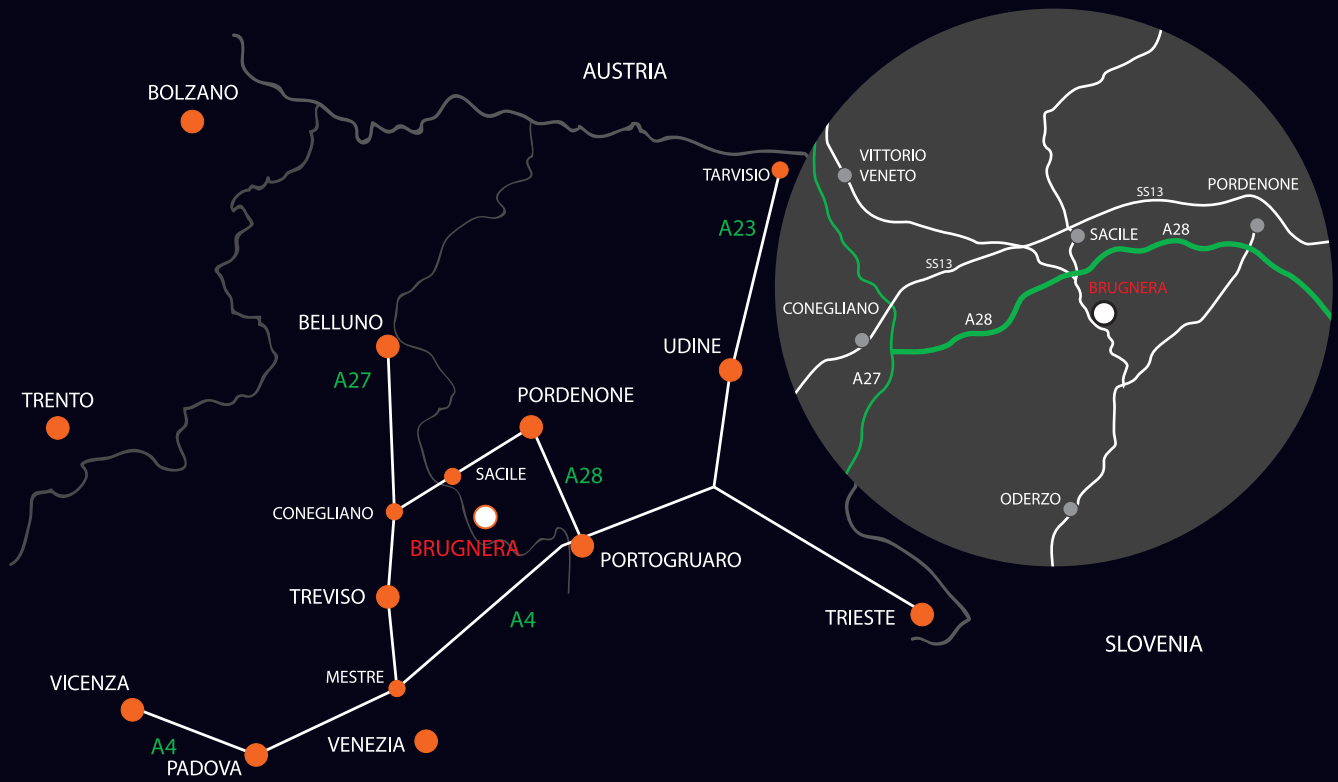

[www.italianaferramenta.com](http://www.italianaferramenta.com)