

mover

Sistema di scorrimento verticale
- portata 6-23 kg.

Vertical sliding system
- capacity 6-23 kg.

Système coulissant vertical
- portée 6-23 kg.

Vertikales Gleitsystem
- Tragfähigkeit 6-23 kg.

Sistema de deslizamiento vertical
- capacidad 6-23 kg.

Montaggio
e regolazione

Assembly and
adjustments

Montage und
Regulierung

Montage
et réglage

Montaje
y regulación

[ITA] INDICE

Caratteristiche tecniche	3
Contenuto imballi	4
Tipologia di prodotto	6
Montaggio degli elementi	7
Preparazione dell'anta	11
Montaggio dell'anta	12
Messa in bolla del mobile	14
Regolazioni dell'anta	15

[ENG] INDEX

Technical features	3
Packaging Contents	4
Type of product	6
Assembling the components	7
Preparation of the door	11
Mounting the door	12
Unit levelling	14
Adjustments the door	15

[FRA] INDEX

Caractéristiques techniques	3
Contenus des emballages	4
Type de produit	6
Montage des éléments	7
Préparation de la porte	11
Montage des porte	12
Mise à niveau du meuble	14
Ajustements des porte	15

[DEU] INHALTSVERZEICHNIS

Technische Eigenschaften	3
Verpackungsinhalt	4
Produkttypologie	6
Montage der Elemente	7
Vorbereitung des Türflügels	11
Montage der Tür	12
Möbel ausrichten	14
Einstellungen der Tür	15

[ESP] ÍNDICE

Características técnicas	3
Relación contenido embalaje	4
Tipo de producto	6
Montaje de los elementos	7
Preparación de la puerta	11
Montaje de las puerta	12
Nivelación del mueble	14
Ajustes de las puerta	15

[ITA] **CARATTERISTICHE TECNICHE**

COMPOSIZIONE MECCANISMO

- › Profili in alluminio: lega 6060T5, anodizzati argento.
- › Componenti per la trasmissione e regolazione (cavetti in fibra vectran, fusioni in zama primaria 15, particolari in plastica stampata).
- › Molle di compensazione.

CARATTERISTICHE ANTE

- › Peso massimo per singola anta 6-23 kg (uniformemente distribuito).
- › Larghezza: 900-1200-1800-2400 mm.
- › Altezza: 480-600 mm.
- › Materiale: a) legno o derivati;
b) telaio in alluminio e vetro.

[ENG] **TECHNICAL FEATURES**

FEATURES OF THE MECHANISM

- › Aluminium profiles: 6060T5 alloy, silver anodised.
- › Components for the transmission and regulation (cables in VECTRAN fiber; components in ZAMAC 15 alloy, components in pressed plastic).
- › Compensation spring.

DOOR FEATURES

- › Maximum weight for each door 6-23 kg (evenly distributed).
- › Width: 900-1200-1800-2400 mm.
- › Height: 480-600 mm.
- › Material: a) wood or derived material;
b) glass with aluminium frame.

[FRA] **CARACTÉRISTIQUES TECHNIQUES**

COMPOSITION DU MÉCANISME

- › Profilés en aluminium : alliage 6060T5 anodisés argent.
- › Composants pour la transmission et le réglage (câbles en fibre vectran, fusions en zamak primaire 15, pièces en plastique moulé).
- › Ressorts de compensation.

CARACTÉRISTIQUES DES PORTES

- › Poids maximum par porte 6-23 kg (Réparti de manière uniforme).
- › Largeur : 900-1200-1800-2400 mm.
- › Hauteur : 480-600 mm.
- › Matériau : a) bois ou produits dérivés ;
b) cadre en aluminium ou en verre.mm.

[DEU] **TECHNISCHE EIGENSCHAFTEN**

ZUSAMMENSETZUNG DES MECHANISMUS

- › Profile aus Aluminium: Legierung 6060T5, eloxiert, silber.
- › Bauteile für Übertragung und Einstellung (Seile in Vectran, Schiebelelemente in Zama-druckguss 15, Bauteile in Kunststoff).
- › Ausgleichsfeder.

EIGENSCHAFTEN DER TÜREN

- › Maximales Gewicht pro Tür 6-23 kg (gleichmäßig verteilt).
- › Breite: 900-1200-1800-2400 mm.
- › Höhe 480-600 mm.
- › Material: a) Holz oder Holzprodukte;
b) Rahmen aus Aluminium oder Glas.

[ESP] **CARACTERÍSTICAS TÉCNICAS**

COMPOSICIÓN DEL MECANISMO

- › Perfiles de aluminio: aleación 6060T5, anodizados en plata.
- › Componentes para la transmisión y regulación (cables de fibra vectran, fusiones en zamak primario 15, detalles de plástico estampado).
- › Resortes de compensación.

CARACTERÍSTICAS DE LAS PUERTAS

- › Peso máximo para cada puerta 6-23 kg (uniformemente distribuido).
- › Anchura: 900-1200-1800-2400 mm.
- › Altura: 480-600 mm.
- › Material: a) madera o derivados;
b) bastidor de aluminio y vidrio.

[ITA] CONTENUTO IMBALLI

[ENG] PACKAGING CONTENTS

[FRA] CONTENUS DES EMBALLAGES

[DEU] VERPACKUNGSIHALT

[ESP] RELACIÓN CONTENIDO EMBALAJE

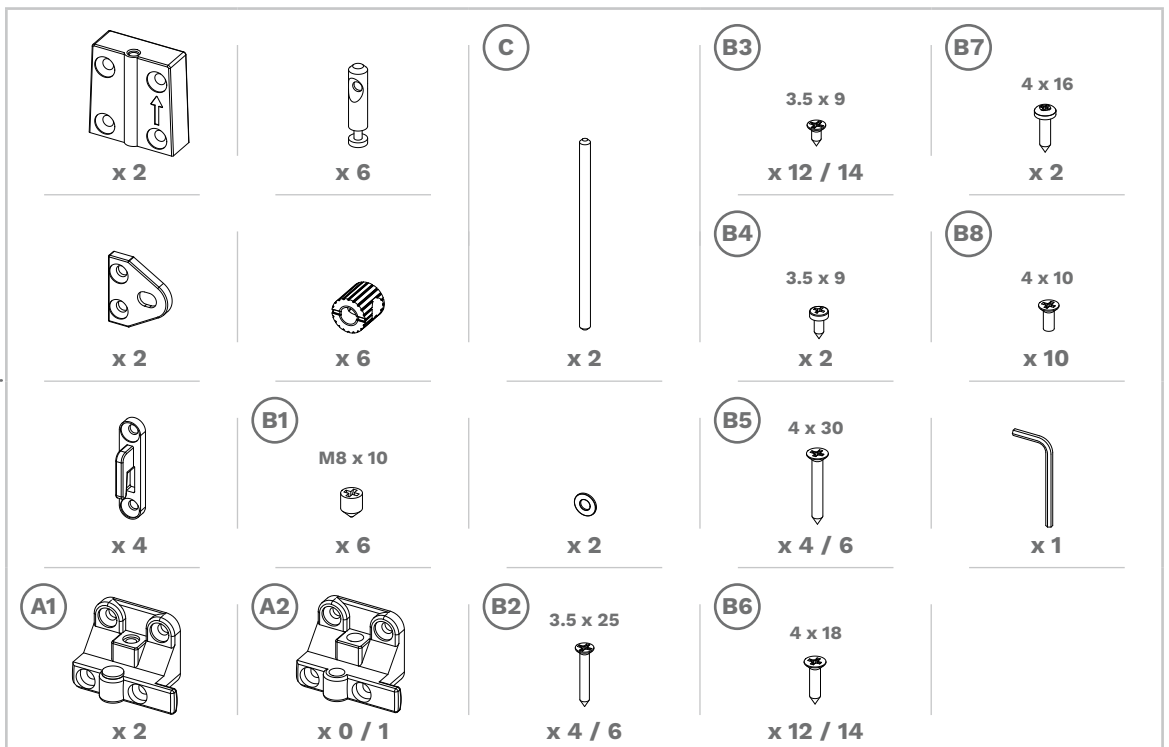
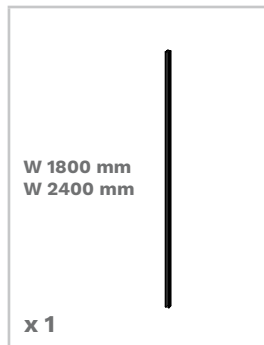
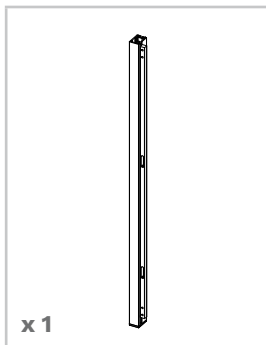
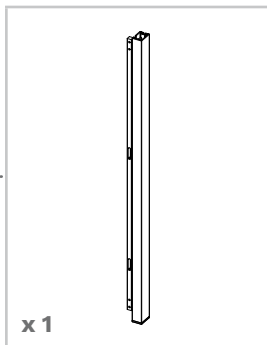
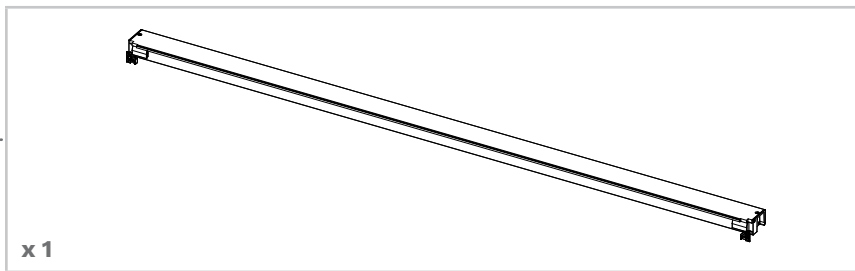
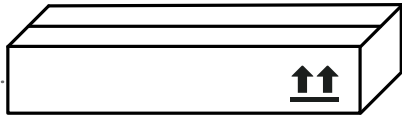

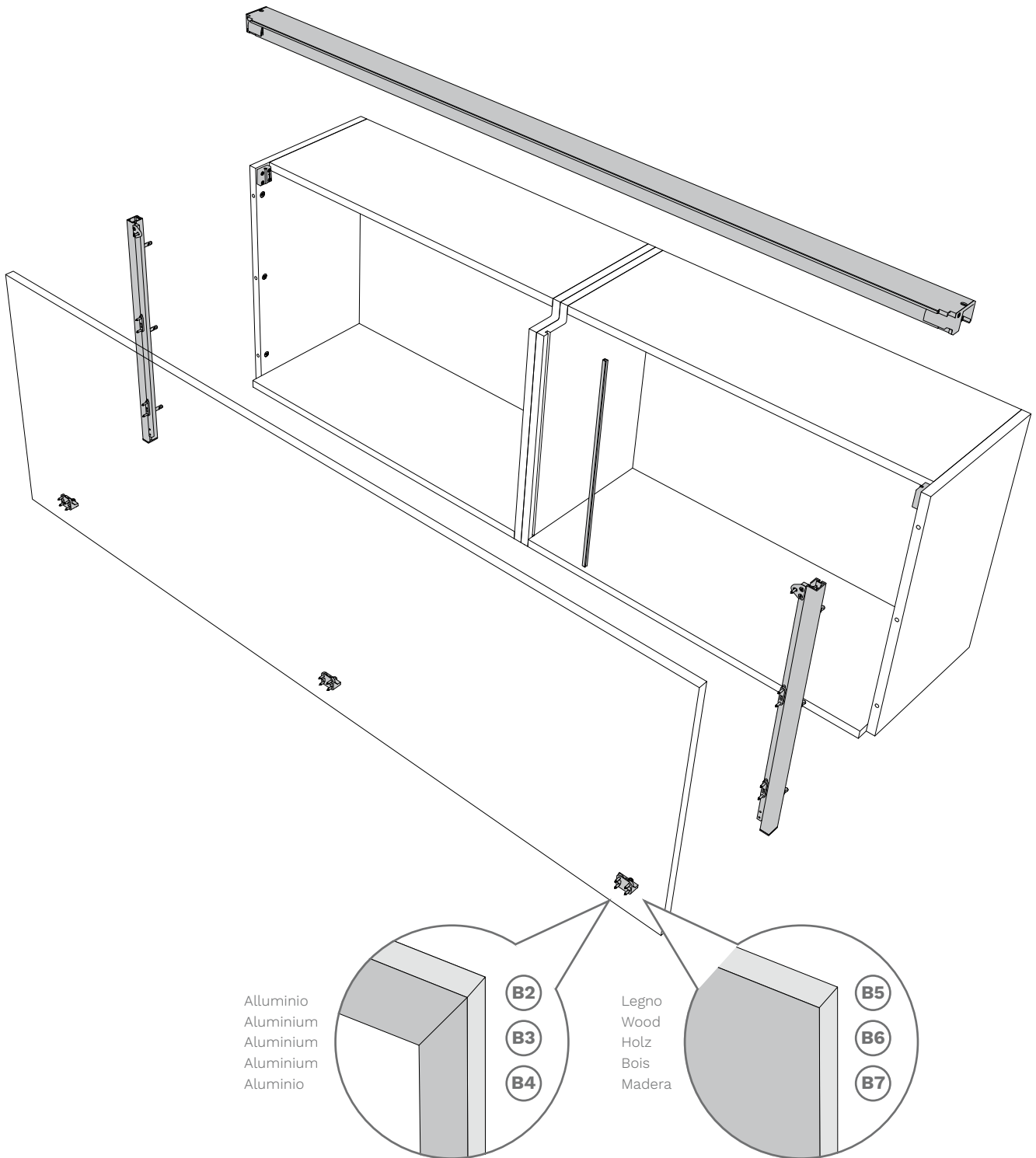

[ITA] TIPOLOGIA DI PRODOTTO

[ENG] TYPE OF PRODUCT

[FRA] TYPE DE PRODUIT

[DEU] PRODUKTTYPOLOGIE

[ESP] TIPO DE PRODUCTO

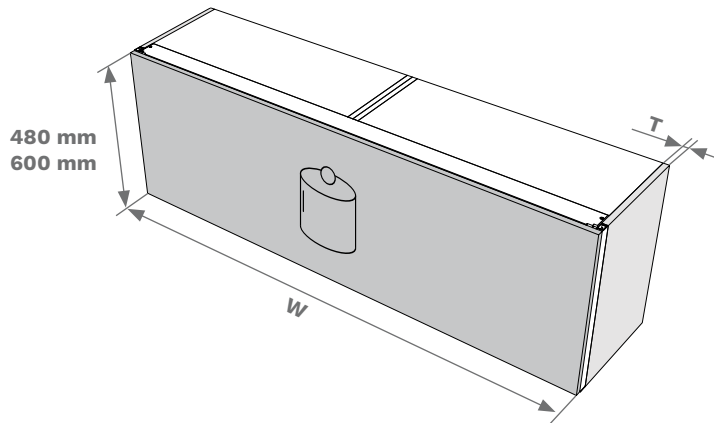

Cod.	Articolo Item Artikel Article Artículo	T (mm)	W (mm)	(kg)
------	--	-----------	-----------	------

480 mm

VE2809004818	MOVER SYSTEM 900 x 480 mm	18	900	6-8
VE2812004818	MOVER SYSTEM 1200 x 480 mm	18	1200	7-9
VE2818004818	MOVER SYSTEM 1800 x 480 mm	18	1800	10-12
VE2824004818	MOVER SYSTEM 2400 x 480 mm	18	2400	15-17
VE2809004820	MOVER SYSTEM 900 x 480 mm	20	900	6-8
VE2812004820	MOVER SYSTEM 1200 x 480 mm	20	1200	7-9
VE2818004820	MOVER SYSTEM 1800 x 480 mm	20	1800	10-12
VE2824004820	MOVER SYSTEM 2400 x 480 mm	20	2400	15-17

600 mm

VE2809006018	MOVER SYSTEM 900 x 600 mm	18	900	6-8
VE2812006018	MOVER SYSTEM 1200 x 600 mm	18	1200	10-12
VE2818006018	MOVER SYSTEM 1800 x 600 mm	18	1800	15-17
VE2824006018	MOVER SYSTEM 2400 x 600 mm	18	2400	21-23
VE2809006020	MOVER SYSTEM 900 x 600 mm	20	900	6-8
VE2812006020	MOVER SYSTEM 1200 x 600 mm	20	1200	10-12
VE2818006020	MOVER SYSTEM 1800 x 600 mm	20	1800	15-17
VE2824006020	MOVER SYSTEM 2400 x 600 mm	20	2400	21-23

[ITA] MONTAGGIO DEGLI ELEMENTI

[ENG] ASSEMBLING THE COMPONENTS

[FRA] MONTAGE DES ÉLÉMENTS

[DEU] MONTAGE DER ELEMENTE

[ESP] MONTAJE DE LOS ELEMENTOS

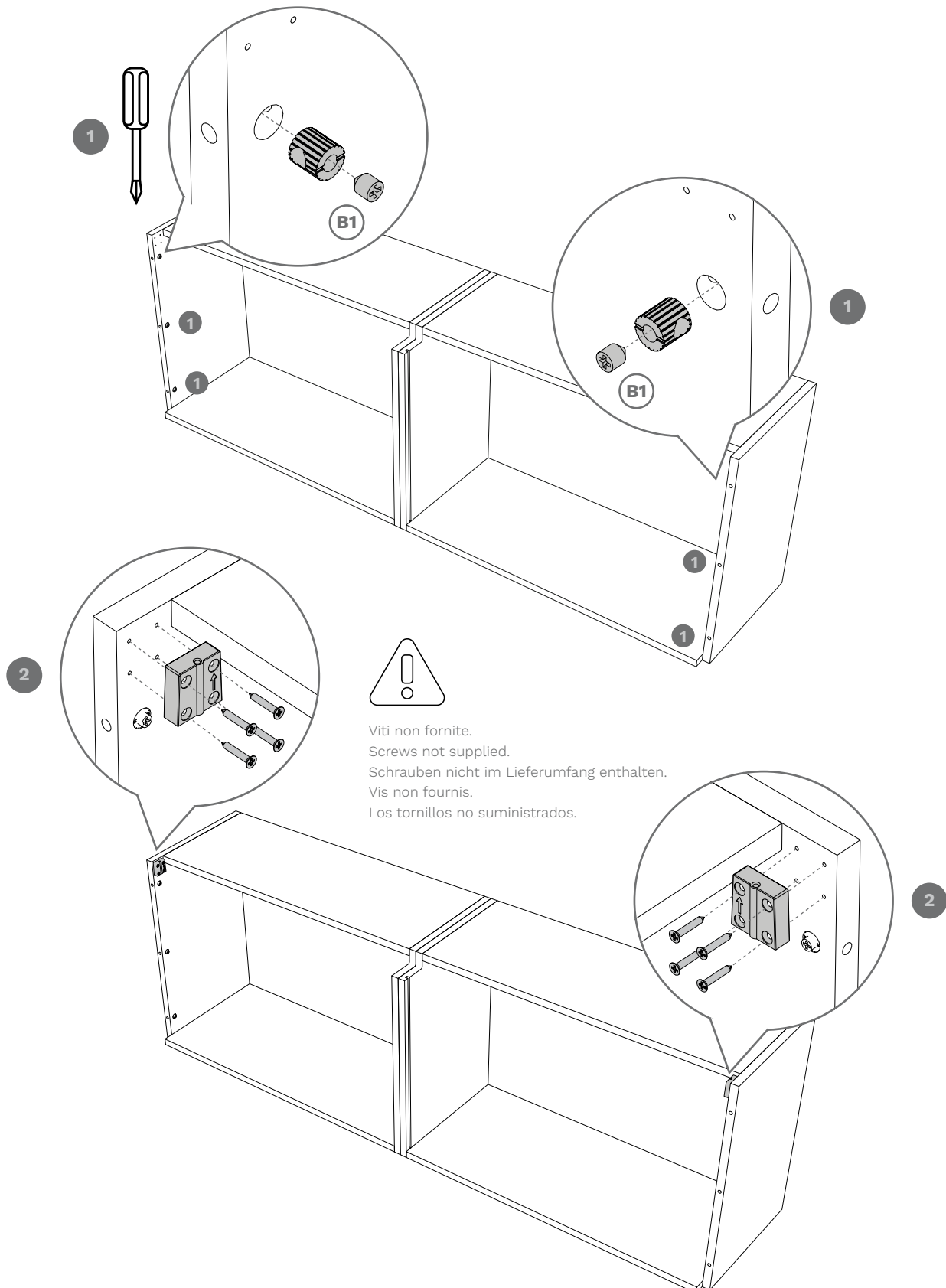

[ITA] MONTAGGIO DEGLI ELEMENTI

[ENG] ASSEMBLING THE COMPONENTS

[FRA] MONTAGE DES ÉLÉMENTS

[DEU] MONTAGE DER ELEMENTE

[ESP] MONTAJE DE LOS ELEMENTOS

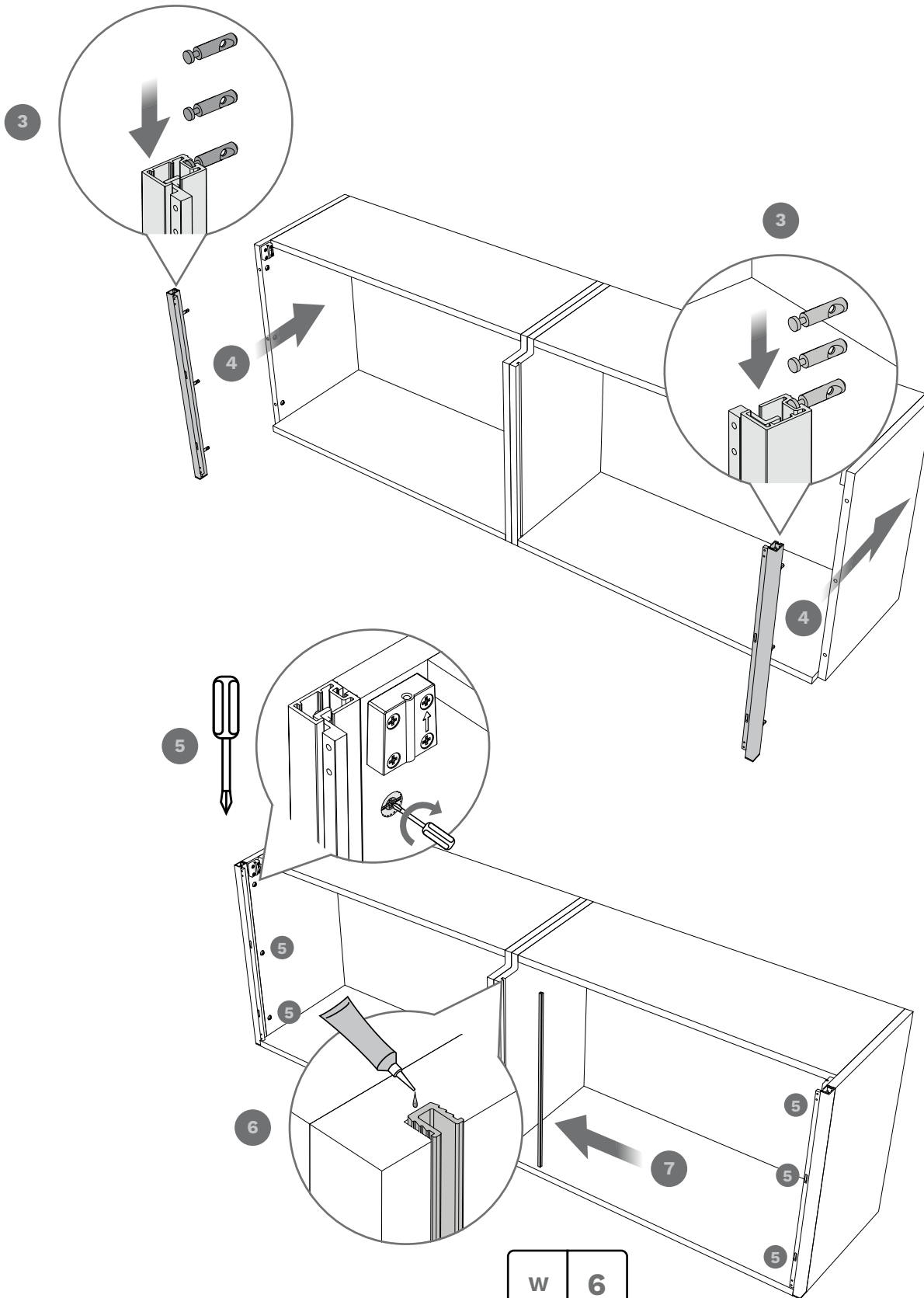

W	6
---	---

W 1800-2400 mm

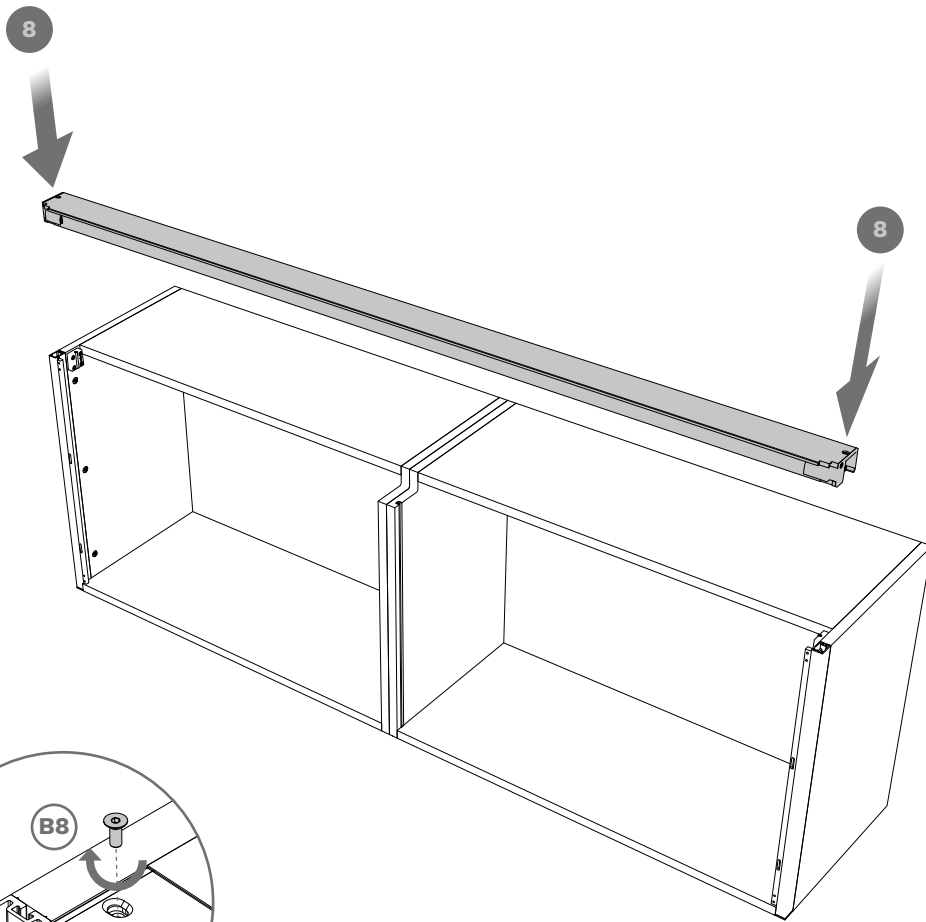

9

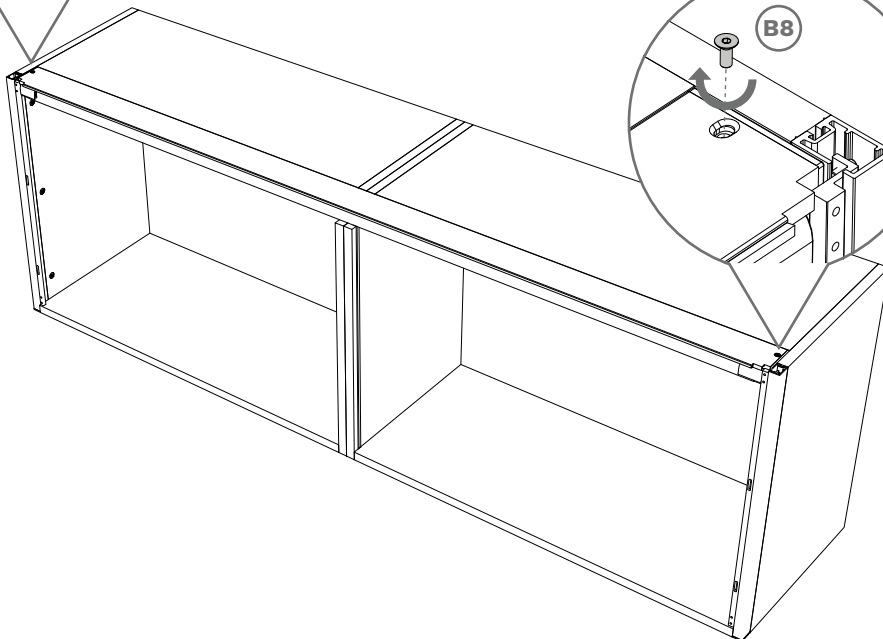
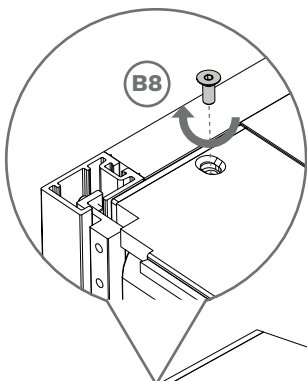

9



[ITA] MONTAGGIO DEGLI ELEMENTI

[ENG] ASSEMBLING THE COMPONENTS

[FRA] MONTAGE DES ÉLÉMENTS

[DEU] MONTAGE DER ELEMENTE

[ESP] MONTAJE DE LOS ELEMENTOS

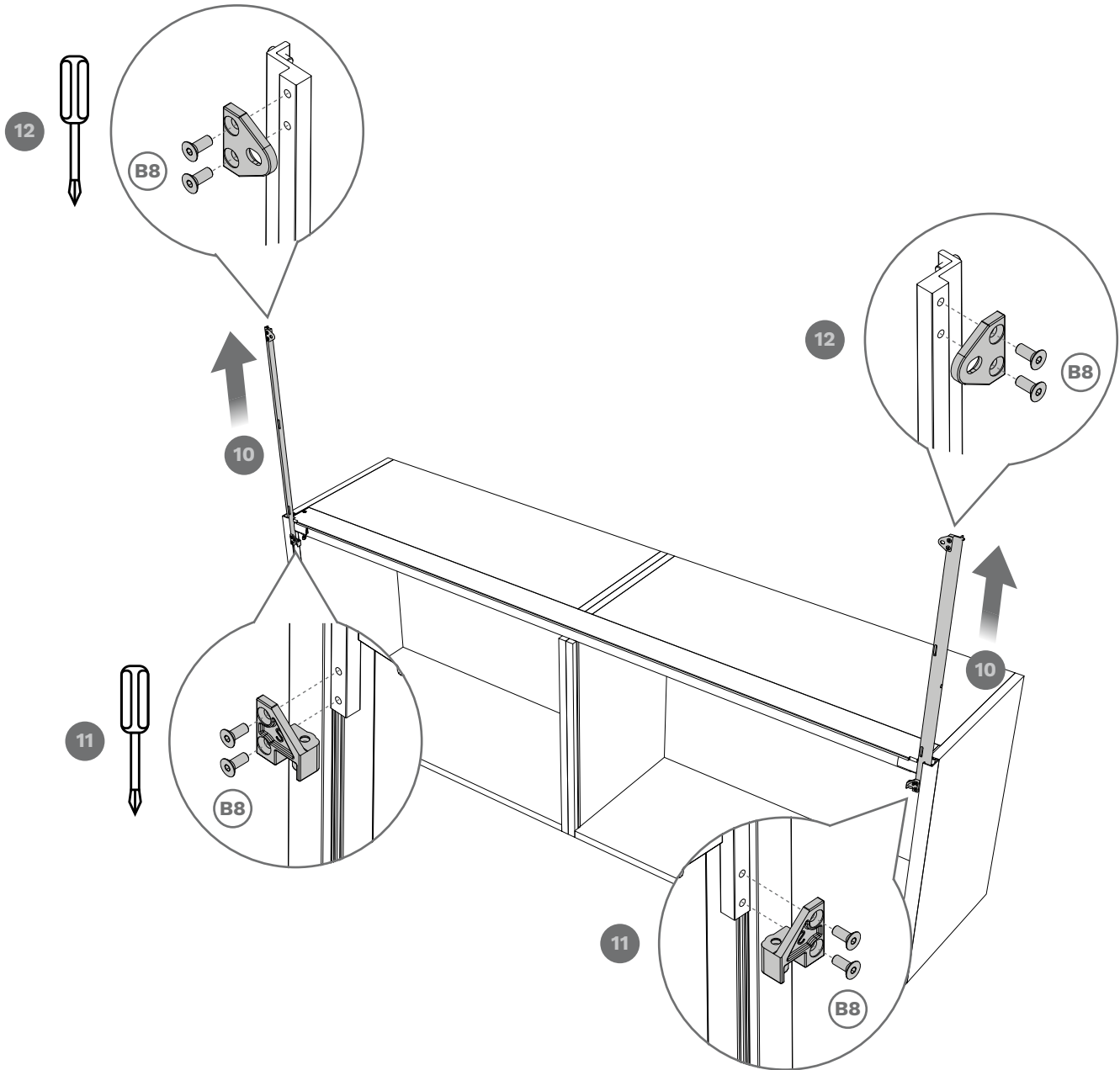

[ITA] PREPARAZIONE DELL'ANTA

[ENG] PREPARATION OF THE DOOR

[FRA] PRÉPARATION DE LA PORTE

[DEU] VORBEREITUNG DES TÜRFLÜGELS

[ESP] PREPARACIÓN DE LA PUERTA

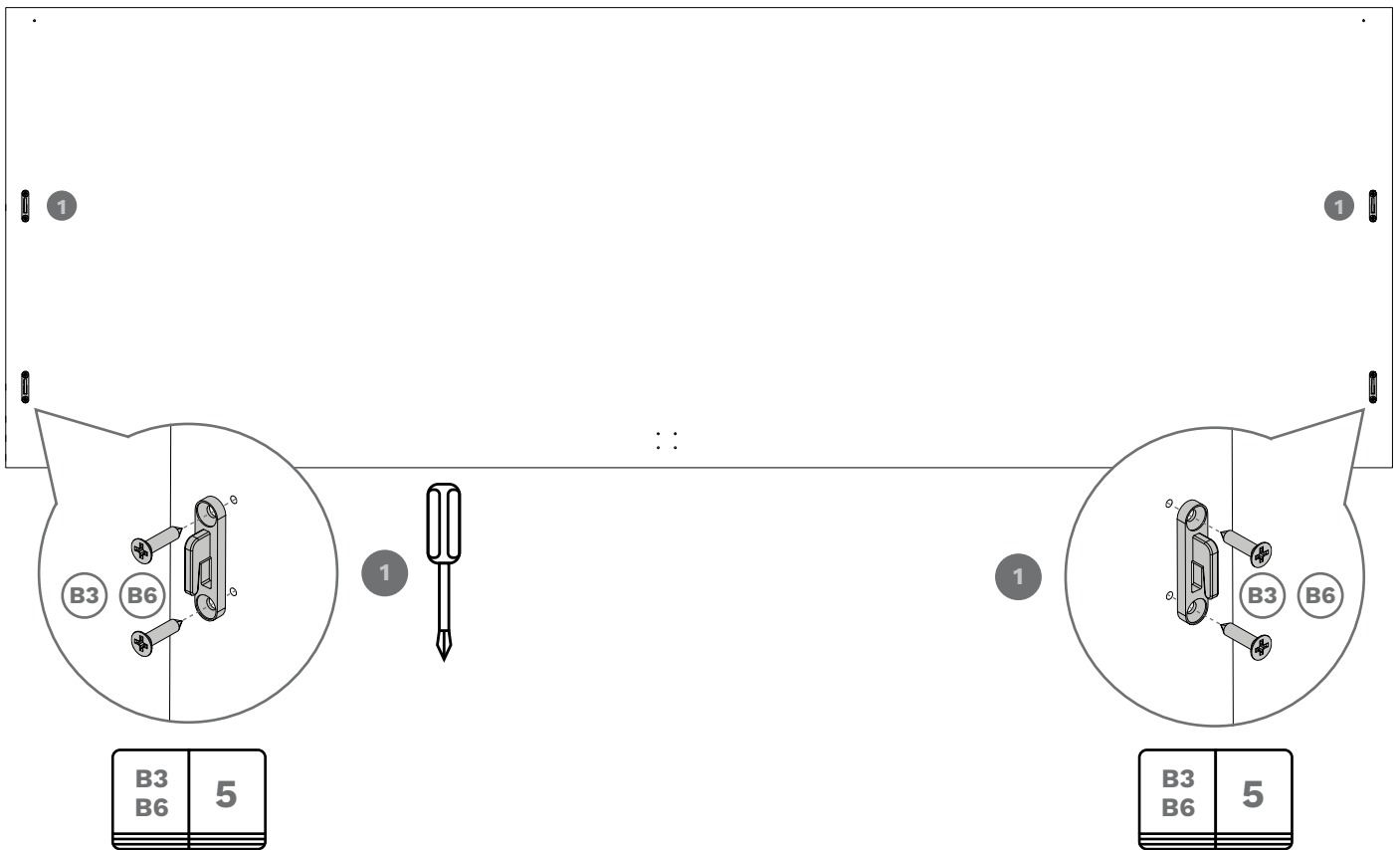

[ITA] MONTAGGIO DELL'ANTA

[ENG] MOUNTING THE DOOR

[FRA] MONTAGE DES PORTE

[DEU] MONTAGE DER TÜR

[ESP] MONTAJE DE LAS PUERTA

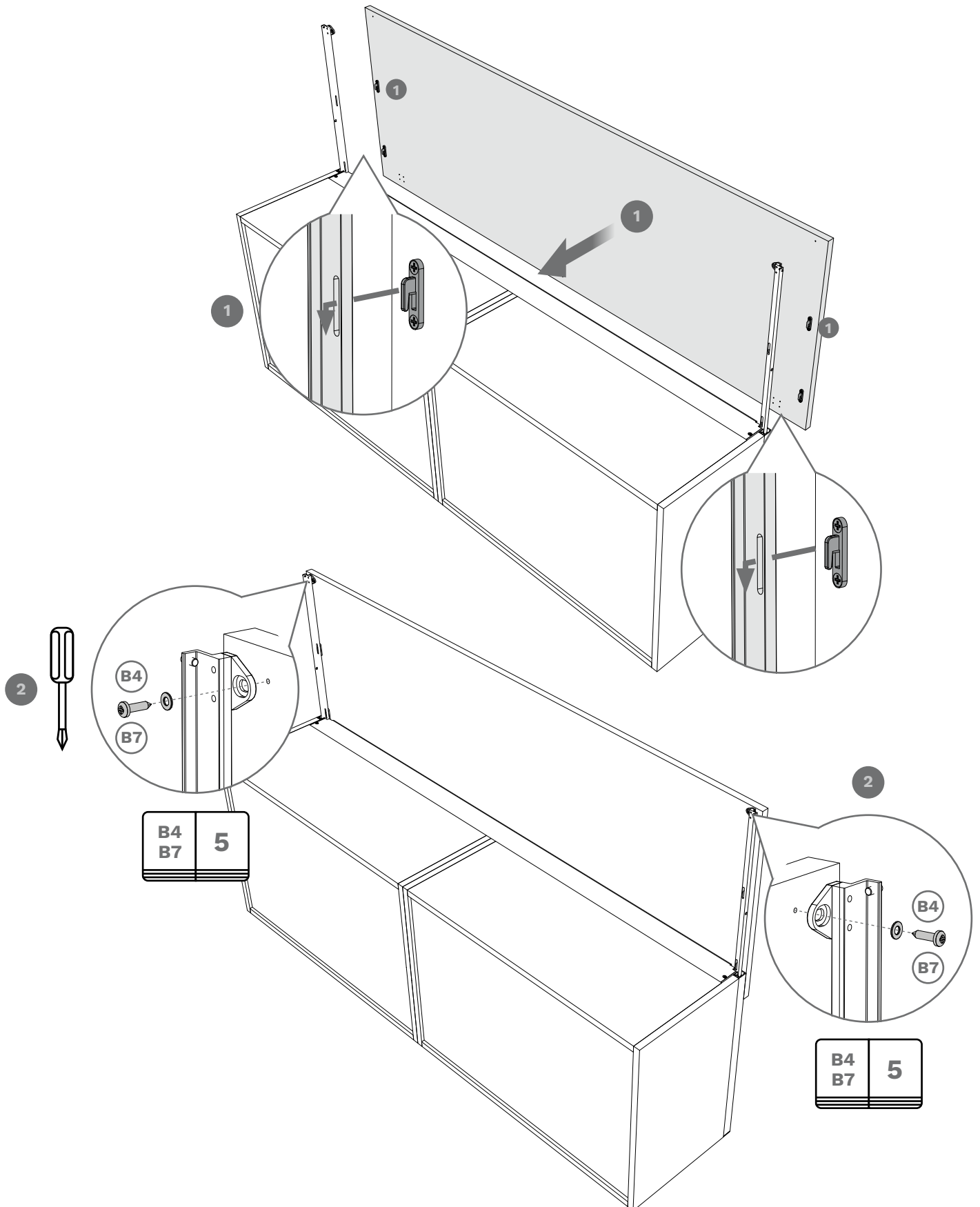

[ITA] MONTAGGIO DELL'ANTA
W 900-1200 MM

[ENG] MOUNTING THE DOOR
W 900-1200 MM

[FRA] MONTAGE DES PORTE
W 900-1200 MM

[DEU] MONTAGE DER TÜR
W 900-1200 MM

[ESP] MONTAJE DE LAS PUERTA
W 900-1200 MM

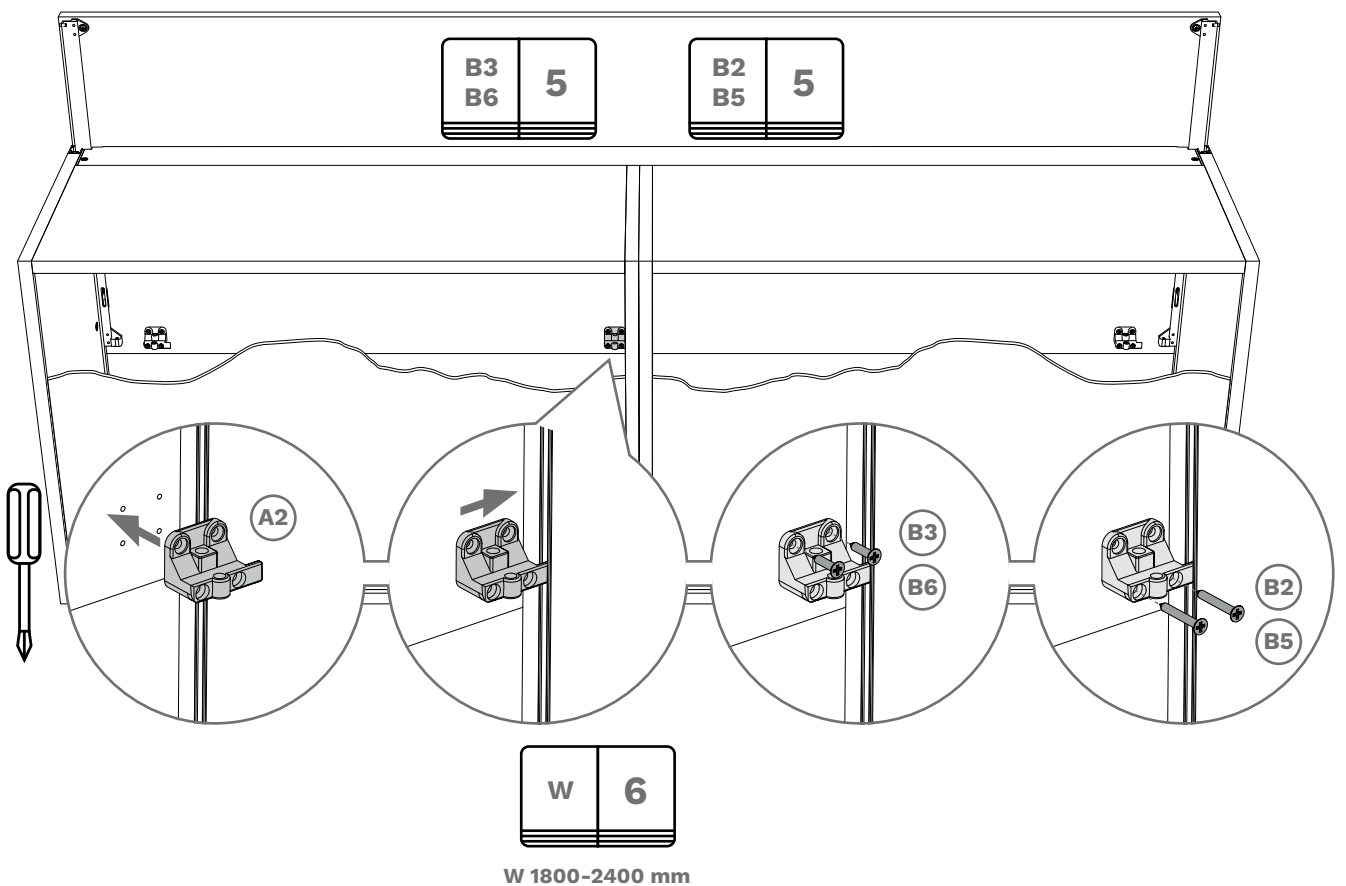
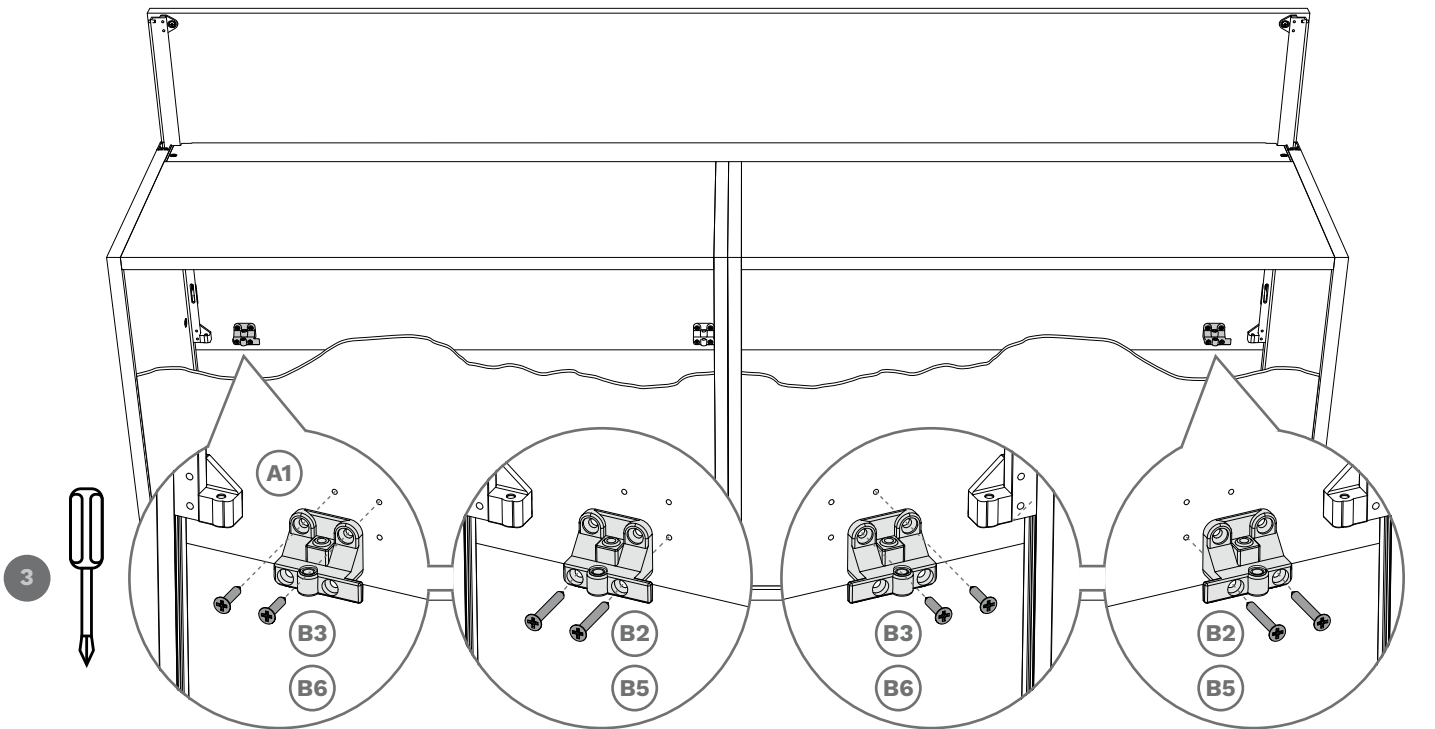

[ITA] MESSA IN BOLLA DEL MOBILE

[ENG] UNIT LEVELLING

[FRA] MISE À NIVEAU DU MEUBLE

[DEU] MÖBEL AUSRICHTEN

[ESP] NIVELACIÓN DEL MUEBLE

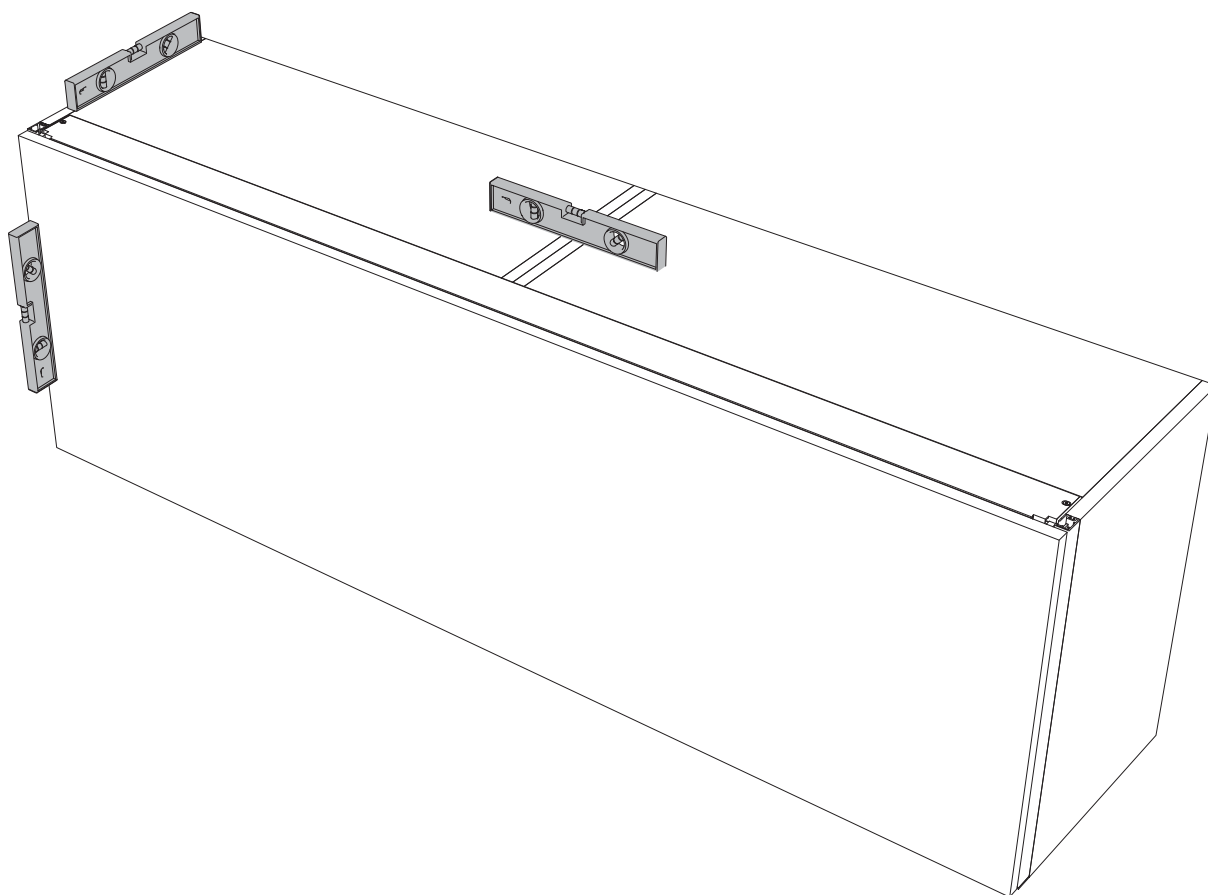

[ITA] REGOLAZIONE DEL PARALLELISMO
TRA ANTA E STRUTTURA

[ENG] PARALLELISM ADJUSTMENT
BETWEEN DOOR AND CABINET

[FRA] RÉGLAGE DU PARALLÉLISME
ENTRE LA PORTE ET LA STRUCTURE

[DEU] EINSTELLUNG DES
PARALLELISMUS ZWISCHEN TÜR UND
STRUKTUR

[ESP] REGULACIÓN DEL PARALELISMO
ENTRE PUERTA Y ESTRUCTURA

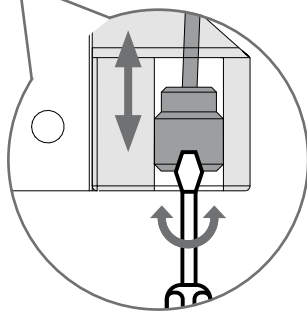
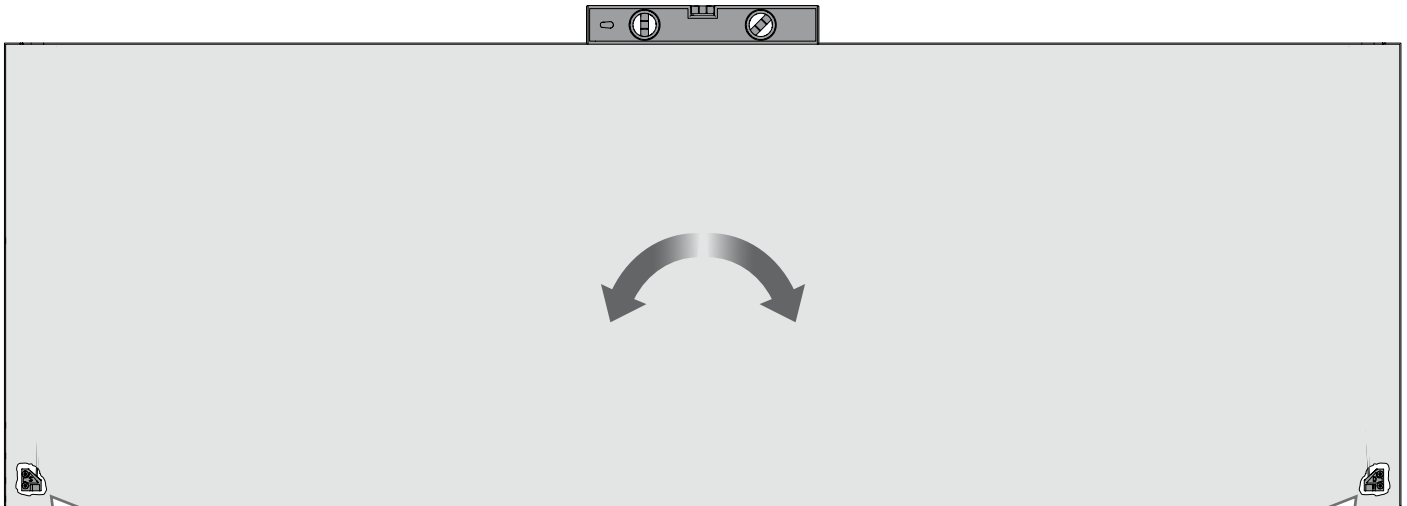

1



max 6 mm

1

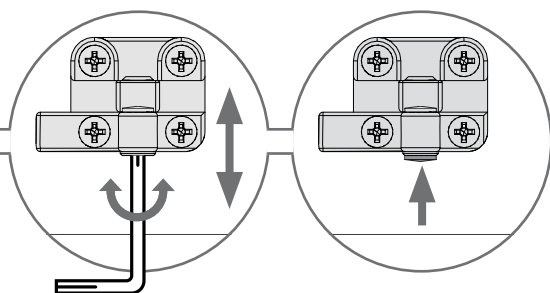
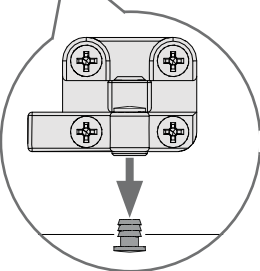
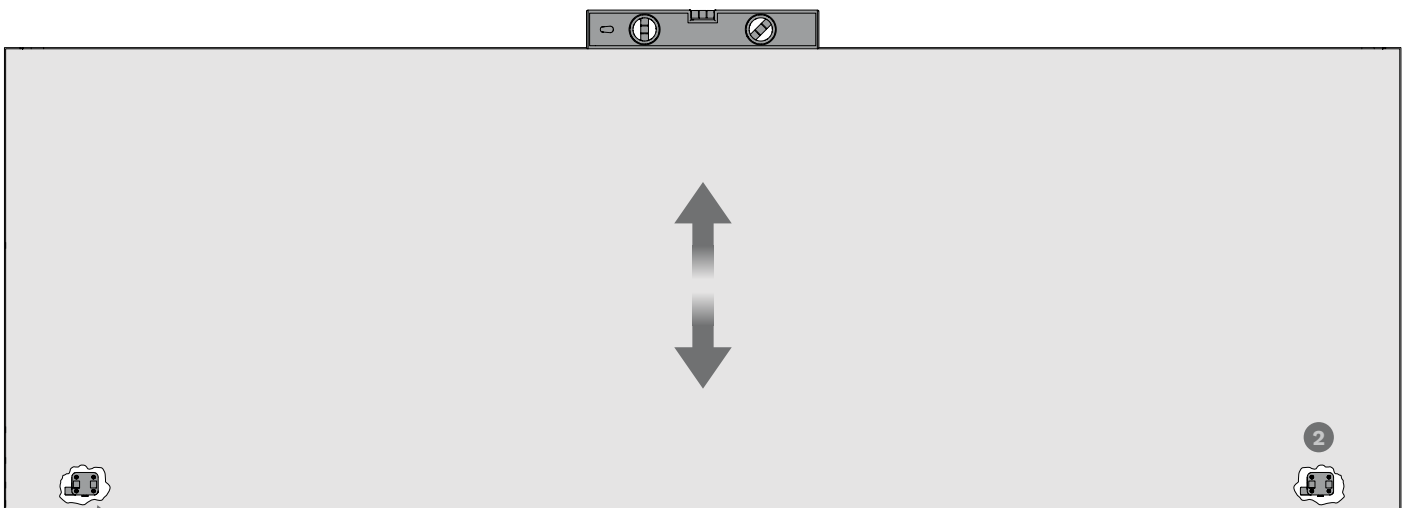
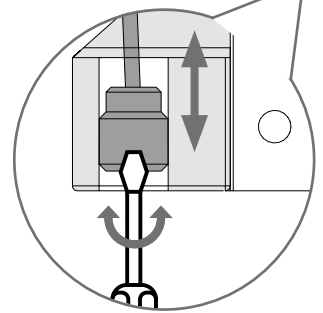

2

max 4 mm

2



[ITA] **REGOLAZIONE VERTICALE DELL'ANTA**

L'anta in posizione di chiusura tende a salire.

[ENG] **VERTICAL ADJUSTMENT OF THE DOOR**

Door in closed position tends to come up.

Bei geschlossener Türe, bleibt diese leicht offen.

[FRA] **RÉGLAGE VERTICAL DE LA PORTE**

La porte en position de fermeture a tendance à monter.

[ESP] **REGULACIÓN VERTICAL DE LA PUERTA**

La puerta en posición de cierre tiende a subir.

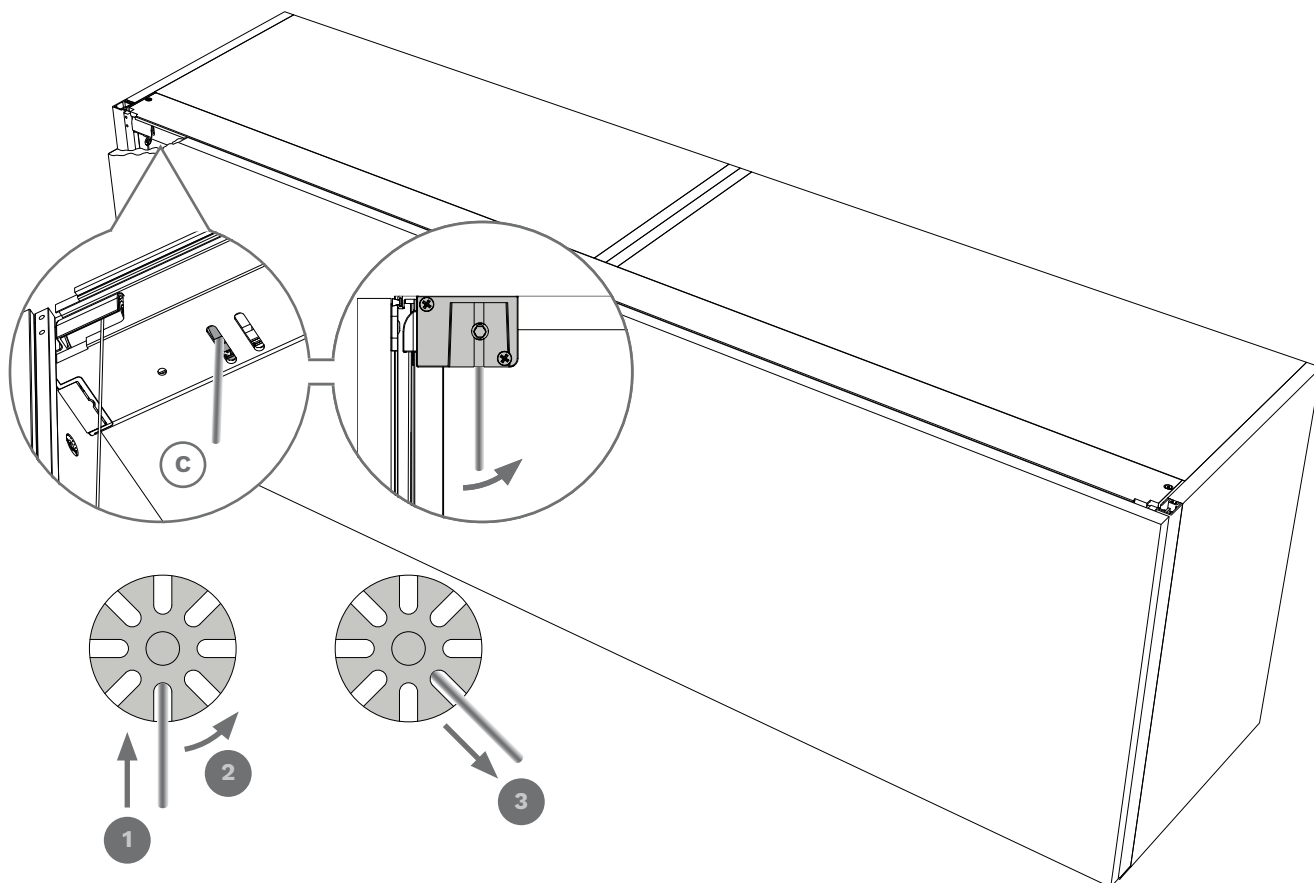

L'anta in posizione di apertura tende a scendere.

Door in open position tends to go down..

La porte en position d'ouverture a tendance à monter.

Bei offener Türe, zieht diese leicht unten.

La puerta en posición de apertura tiende a bajar.

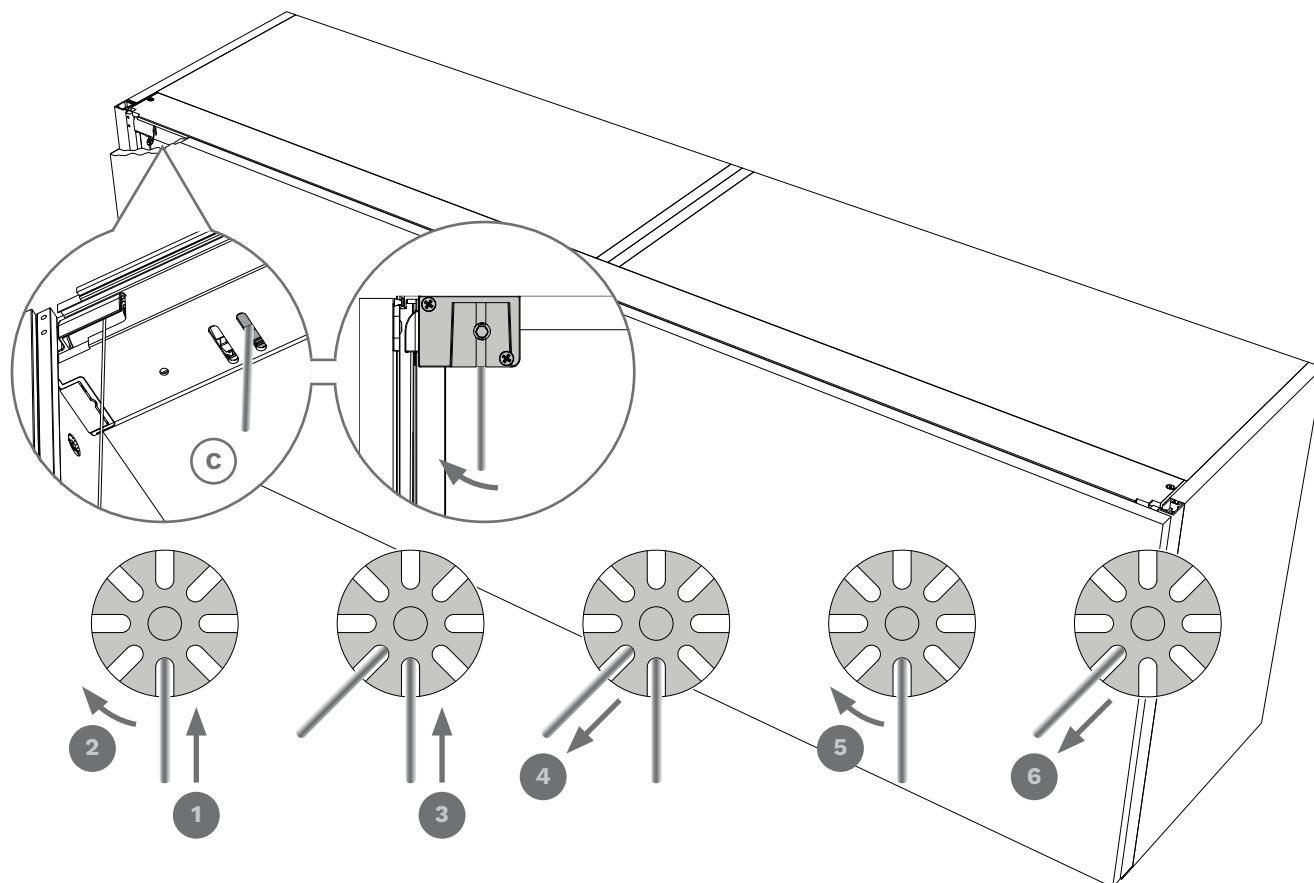

[ITA] PULIZIA

La pulizia dei componenti deve essere eseguita con un panno morbido inumidito con acqua e sapone. Vanno evitati prodotti contenenti solventi e componenti abrasivi.

SMALTIMENTO

Una volta dismesso, il prodotto e i suoi componenti non vanno dispersi nell'ambiente, ma conferiti ai sistemi pubblici di smaltimento.

NOTA

Bortoluzzi si riserva il diritto di apportare modifiche tecniche senza preavviso.

[ENG] CLEANING

The components must be cleaned using a soft cloth with soap and water. Avoid using products containing solvents and abrasive products.

DISPOSAL

The product and its components must not be disposed of in the environment; for disposal, please use public disposal systems.

NOTE

Bortoluzzi reserves the right to modify any product without prior notice.

[DEU] REINIGUNG

Die Reinigung der Bauteile wird mit einem mit Wasser und Seife befeuchteten, weichen Tuch ausgeführt.

ENTSORGUNG

Die Produkte und die Produktteile, die nicht mehr eingesetzt werden, sollen nicht in die Umwelt gelangen, sondern an den geeigneten Stellen entsorgt werden.

HINWEIS

Bortoluzzi behält sich das Recht vor, ohne vorherige Ankündigung technische Änderungen durchzuführen.

[FRA] NETTOYAGE

Le nettoyage des composants doit être effectué avec un chiffon doux imbibé d'eau et de savon. Il faut éviter les produits contenant des solvants et des composants abrasifs.

ÉLIMINATION

Une fois jeté, le produit et ses composants ne peuvent pas être dispersés dans l'environnement naturel mais confiés au service public de gestion des déchets.

REMARQUE

Bortoluzzi se réserve le droit d'apporter des modifications techniques sans préavis.

[ESP] LIMPIEZA

La limpieza de los componentes debe realizarse con un paño suave humedecido con agua y jabón. Hay que evitar productos que contengan disolventes y componentes abrasivos.

ELIMINACIÓN

Una vez en desuso, el producto y sus componentes no se deben echar en el medio ambiente, ya que deben entregarse a los sistemas públicos de eliminación de residuos.

NOTA

Bortoluzzi se reserva el derecho de realizar modificaciones técnicas sin preaviso.

mover



bortoluzzi

Moving silence

Bortoluzzi Sistemi SPA
via Caduti 14 Settembre 1944, n°45
32100 Belluno - Italy
tel +39 0437 930866
fax +39 0437 931442
info@bortoluzzi.com
www.bortoluzzi.com

