

## Slider M50 Flex



**Slider M50 Flex** is the coplanar system for doors weighing up to 50 kg which is designed to be cut to length. Thanks to the exclusive patented design of the Slider series, door movement and cushioned opening and closing are intuitive, smooth and silent. **Slider M50 Flex** also offers extreme flexibility: the length of mechanism can be adjusted to fit any cabinet by simply cutting the track as required.

**Slider M50 Flex** is the new addition to the coplanar range and, with just a small range of components, it confers the freedom to tailor the mechanism to suit any piece of furniture to perfection.



## Slider M50 Flex



### Technical information

Coplanar two-door cushioned sliding system with customisable track length  
- capacity 50 kg per door.

#### Door dimensions:

- Maximum weight for each door 50 kg (evenly distributed).
- Width: - minimum 800 mm;  
- maximum 1600 mm.
- Height: - maximum 2700 mm.
- Thickness: - minimum 18 mm;  
- maximum with handle 40 mm.
- Height from the ground:  
- 33 mm.
- Material: a) wood or derived material;  
b) glass with metal frame.

#### Door adjustment:

- vertical  $\pm 5$  mm
- horizontal  $\pm 3,5$  mm
- front: - upper  $\pm 3$  mm  
- lower  $\pm 3$  mm

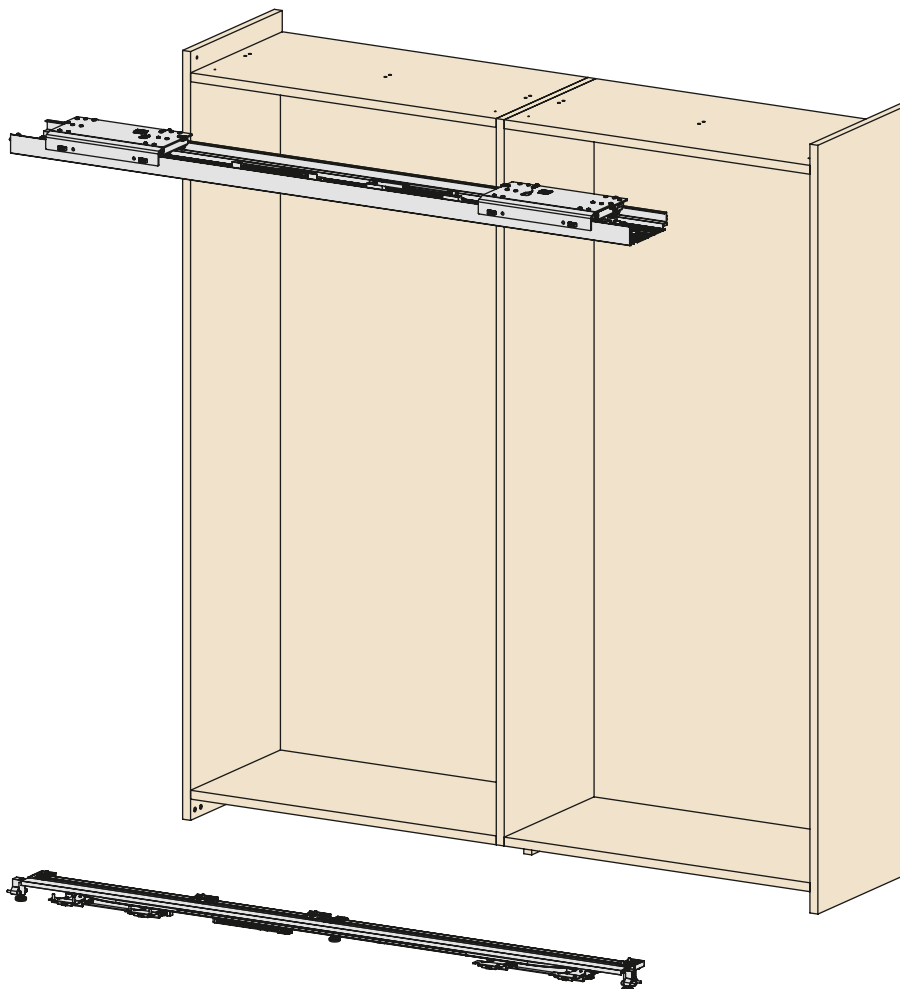

### Key feature

- Very easy to assemble.
- Extremely easy to personalise the track length.
- Super-smooth cushioned opening and closing
- High reliability, tested to 100,000 cycles.

